

TT301

smar

AUG / 20
TT301
VERSION 3

OPERATION & MAINTENANCE INSTRUCTIONS MANUAL

Intelligent Temperature Transmitter with Control Capability Optional

HART 
COMMUNICATION PROTOCOL

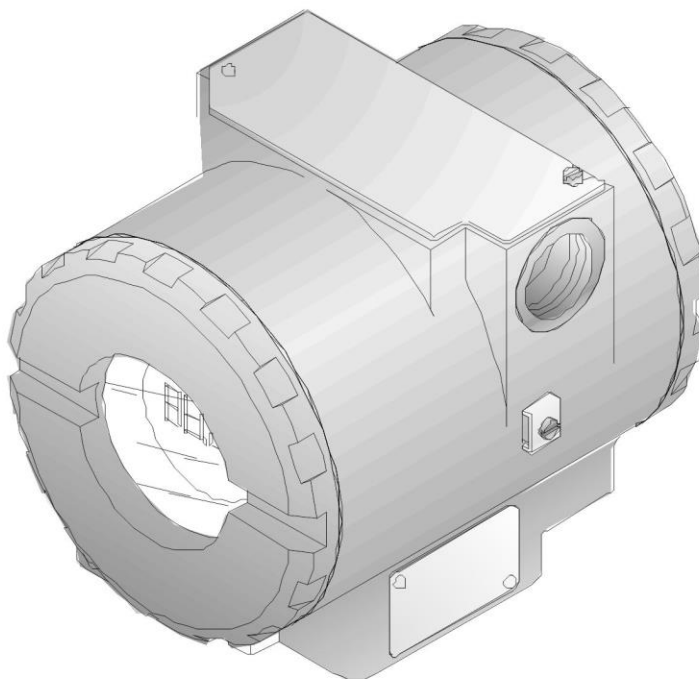

TT301ME

smar
NOVA SMAR S/A
www.smar.com.br

Specifications and information are subject to change without notice.
Up-to-date address information is available on our website.

web: www.smar.com/contactus.asp

INTRODUCTION

The **TT301** is a transmitter mainly intended for measurement of temperature using RTDs or thermocouples, but can also accept other sensors with resistance or mV output such as: pyrometers, load cells, resistance position indicators, etc. The digital technology used in the **TT301** enables the choice of several output functions, an easy interface between the field and the control room and several interesting features that reduce considerably the installation, operation and maintenance costs.

The **TT301**, besides the normal functions offered by other smart transmitters, offers the following functions:

SPECIAL SENSOR: the output follows a mV or Ohm input according to a 16-point linearization table.

PID OUTPUT CHARACTERIZATION: the PID output signal (MV) follows a curve determined by 16 points.

BACKUP SENSOR: the process measurement is realized by two sensors, but only one supplies the temperature. If it failure the other take its place.

INPUT SELECTOR: the selection between two sensor to obtain the measure is configured by user based in the conditions of maximum, minimum or average temperature of the sensor.

CONTROLLER: the process variable is compared to a setpoint. The deviation acts on the output signal according to a PID algorithm (Optional).

BATCH : setpoint generator allowing pre-programmed recipes of up to 2-week duration in 16 points.

LOCAL ADJUST: allow to set lower and upper value, sensor type, operation mode, indication, setpoint, PID parameters without a configurator.

PASSWORD : three configurable levels for different functions.

CHANGE COUNTER: indicates the number of changes in each functions.

SPECIAL- SENSOR-UNIT: allows the reading to be indicated by one of 100 standard engineering units or any special unit with up to 5 characters.

Get the best results of the TT301 by carefully reading these instructions.

NOTE:

This Manual is compatible with version 4.XX, where 4 de notes software Version and XX software "RELEASE". The indication 4.XX means that this manual is compatible with any release of software version 4.

Waiver of responsibility

The contents of this manual abides by the hardware and software used on the current equipment version. Eventually there may occur divergencies between this manual and the equipment. The information from this document are periodically reviewed and the necessary or identified corrections will be included in the following editions. Suggestions for their improvement are welcome.

Warning

For more objectivity and clarity, this manual does not contain all the detailed information on the product and, in addition, it does not cover every possible mounting, operation or maintenance cases.

Before installing and utilizing the equipment, check if the model of the acquired equipment complies with the technical requirements for the application. This checking is the user's responsibility.

If the user needs more information, or on the event of specific problems not specified or treated in this manual, the information should be sought from Smar. Furthermore, the user recognizes that the contents of this manual by no means modify past or present agreements, confirmation or judicial relationship, in whole or in part.

All of Smar's obligation result from the purchasing agreement signed between the parties, which includes the complete and sole valid warranty term. Contractual clauses related to the warranty are not limited nor extended by virtue of the technical information contained in this manual.

Only qualified personnel are allowed to participate in the activities of mounting, electrical connection, startup and maintenance of the equipment. Qualified personnel are understood to be the persons familiar with the mounting, electrical connection, startup and operation of the equipment or other similar apparatus that are technically fit for their work. Smar provides specific training to instruct and qualify such professionals. However, each country must comply with the local safety procedures, legal provisions and regulations for the mounting and operation of electrical installations, as well as with the laws and regulations on classified areas, such as intrinsic safety, explosion proof, increased safety and instrumented safety systems, among others.

The user is responsible for the incorrect or inadequate handling of equipments run with pneumatic or hydraulic pressure or, still, subject to corrosive, aggressive or combustible products, since their utilization may cause severe bodily harm and/or material damages.

The field equipment referred to in this manual, when acquired for classified or hazardous areas, has its certification void when having its parts replaced or interchanged without functional and approval tests by Smar or any of Smar authorized dealers, which are the competent companies for certifying that the equipment in its entirety meets the applicable standards and regulations. The same is true when converting the equipment of a communication protocol to another. In this case, it is necessary sending the equipment to Smar or any of its authorized dealer. Moreover, the certificates are different and the user is responsible for their correct use.

Always respect the instructions provided in the Manual. Smar is not responsible for any losses and/or damages resulting from the inadequate use of its equipments. It is the user's responsibility to know and apply the safety practices in his country.

TABLE OF CONTENTS

SECTION 1 - INSTALLATION	1.1
GENERAL	1.1
MOUNTING	1.1
ELECTRONIC HOUSING	1.2
WIRING	1.2
LOOP CONNECTIONS	1.3
INSTALLATION IN HAZARDOUS AREAS	1.7
SECTION 2 - OPERATION	2.1
FUNCTIONAL DESCRIPTION-HARDWARE	2.1
FUNCTIONAL DESCRIPTION - SOFTWARE	2.4
TEMPERATURE SENSORS	2.5
THE DISPLAY	2.7
MONITORING	2.7
ALARM	2.8
SECTION 3 - CONFIGURATION	3.1
CONFIGURATION RESOURCES	3.3
PROGRAMMING TREE	3.3
IDENTIFICATION AND MANUFACTURING DATA – INFO	3.4
CONFIGURATOR - CONF	3.4
CALIBRATION – RANGE	3.4
MAINTENANCE - MAINT	3.4
SENSOR TYPES - SENSOR	3.5
CONNECTION AND WORK MODEL	3.7
SPECIAL SENSOR CONFIGURATION	3.7
PID	3.8
MONITORING - MONIT	3.9
CALIBRATING THE TT301	3.10
CALIBRATION WITHOUT REFERENCE	3.10
CALIBRATION WITH REFERENCE	3.11
UNIT	3.11
DAMPING	3.11
TRIM	3.11
ALARM	3.12
ALARM CONFIGURATION	3.12
ONLINE MULTIDROP OPERATION	3.12
CONFIGURATION TT301 FOR MULTIDROP	3.13
MULTIDROP MODE CONFIGURATION	3.13
SECTION 4 - PROGRAMMING USING LOCAL ADJUSTMENT	4.1
THE MAGNETIC TOOL	4.1
RERANGING USING THE LOCAL ZERO AND SPAN ADJUSTMENTS IN SIMPLE MODE	4.2
COMPLETE LOCAL ADJUSTMENT	4.3
OPERATION [OPER]	4.4
BATCH [BATCH]	4.5
TUNING [TUNE]	4.6
CONFIGURATION [CONF]	4.9
SECTION 5 - MAINTENANCE PROCEDURES	5.1
GENERAL	5.1
DIAGNOSIS WITH SMAR CONFIGURATOR	5.1
ERROR MESSAGES	5.1
DIAGNOSTICS WITH THE CONFIGURATOR	5.1
TROUBLESHOOTING WITH TRANSMITTER	5.2
DISASSEMBLY PROCEDURE	5.3
REASSEMBLY PROCEDURE	5.4
INTERCHANGEABILITY	5.4
RETURNING MATERIALS	5.4
SECTION 6 - TECHNICAL CHARACTERISTIC	6.1
ORDERING CODE	6.5

APPENDIX A - CERTIFICATIONS INFORMATION..... A.1
APPENDIX B – SRF – SERCIVE REQUEST FORM..... B.1

Installation Flowchart

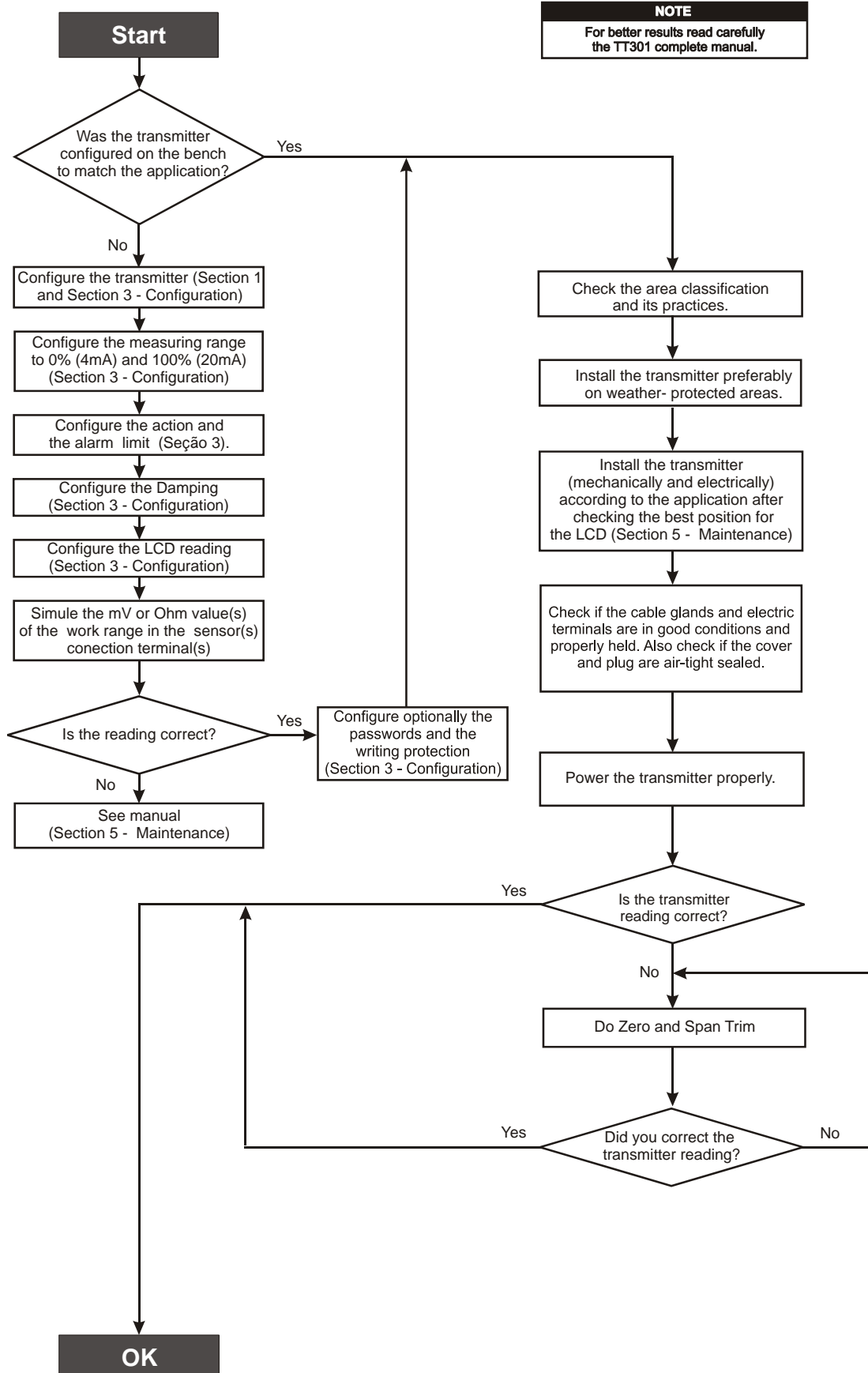

Section 1

INSTALLATION

General

The overall accuracy of temperature and other measurements depends on several variables. Although the transmitter has an outstanding performance, proper installation is essential, in order to maximize its performance.

Among all factors, which may affect transmitter accuracy, environmental conditions are the most difficult to control. There are, however, ways of reducing the effects of temperature, humidity and vibration.

Mounting

Temperature fluctuation effects can be minimized by locating the transmitter in areas protected from extreme environmental changes.

In warm environments, the transmitter should be installed to avoid, as much as possible, direct exposure to the sun. Installation close to lines and vessels subjected to high temperatures should also be avoided. For temperature measurements, sensors with cooling-neck can be used or the sensor can be mounted separated from the transmitter housing.

Use of sunshades or heat shields to protect the transmitter from external heat sources should be considered, if necessary.

The transmitter may be mounted in two basic ways, as follows:

- Separated from the sensor, using optional mounting brackets;
- Mounted on the sensor assembly.

Using the brackets, the mounting may be done in several positions, as shown on Figure 1.1.

Measurement error can be decreased by using proper wires (see Section II, Operation).

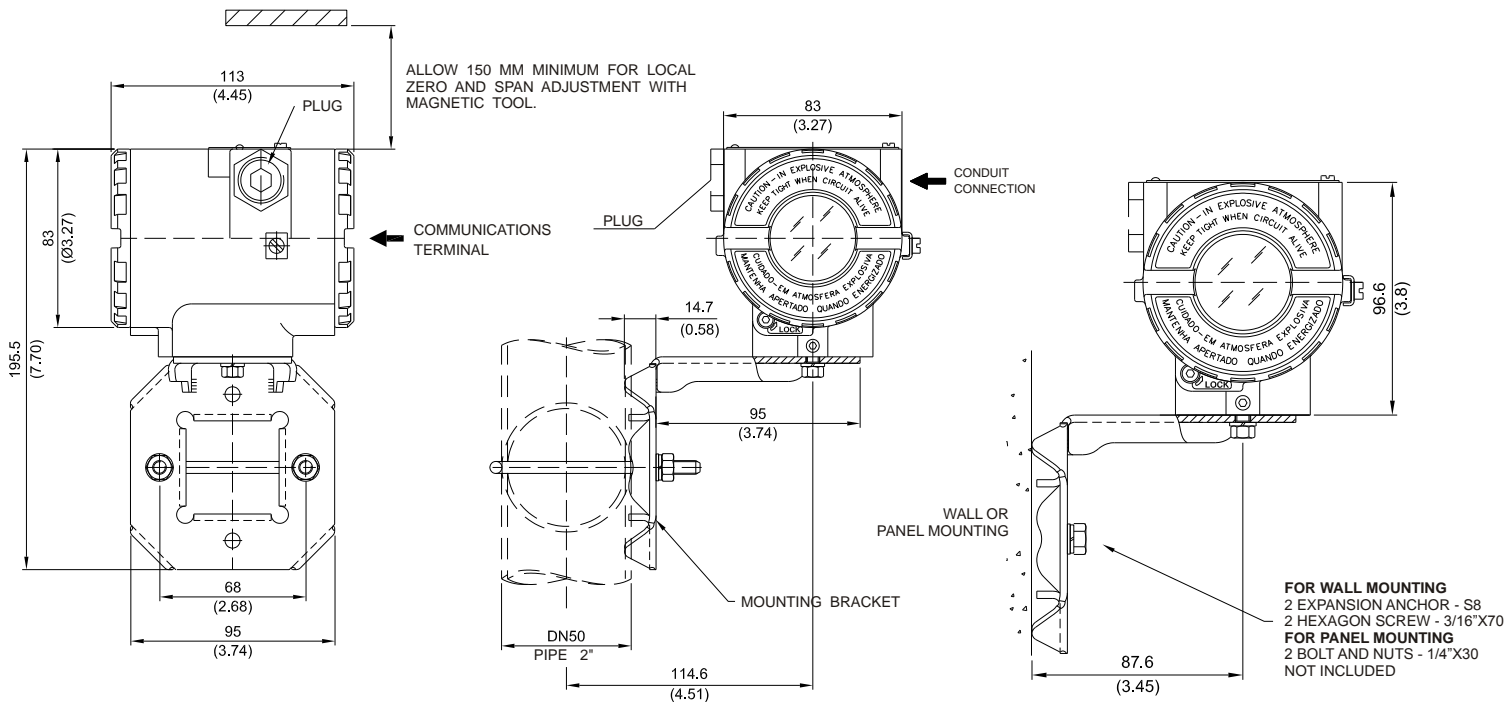

WARNING

Do not remove the graphite grease from the covers, or they may jam.

Electronic Housing

Humidity is fatal to electronic circuits. In areas subjected to high relative humidity, the O-rings for the electronics cover must be correctly placed. Removal of the electronics cover in the field should be reduced to the minimum necessary, since each time it is removed; the circuits are exposed to the humidity.

The electronic circuit is protected by a humidity proof coating, but frequent exposures to humidity may affect the protection provided. It is also important to keep the covers tightened in place. Every time they are removed, the threads are exposed to corrosion, since painting cannot protect these parts. Sealing methods should be employed on conduit entering the transmitter.

One of the conduit inlets for electrical connection is used to mount the sensor integral to the temperature transmitter (see Fig. 1.1).

WARNING

The unused cable entries should be plugged and sealed accordingly to avoid humidity entering, which can cause the loss of the product's warranty.

For better visibility, the digital indicator may be rotated in steps of 90° (see Section 5, Maintenance).

Reach the display and main board by removing the Cover with window. This cover should be locked closed by the cover locking screw. To release the cover, rotate the locking screw clockwise. See figure 1.2.

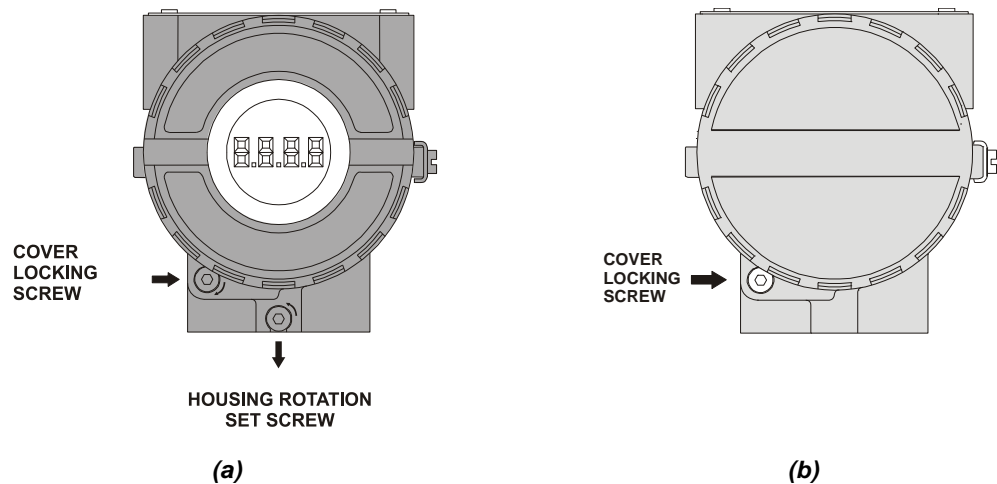

Figure 1.2- Cover Locking and Housing Rotating Set Screw (a) Electronic Board Side (b) Terminal Connection Side

Wiring

Access the wiring block by removing the Electrical Connection Cover. This cover can be locked closed by the cover locking screw (Figure 1.2- b). To release the cover, rotate the locking screw clockwise.

The terminals in the superior part marked with (+) and (-) are to receive the powering from 12 to 45 Vdc. The inferior terminals marked with the numbers from 1 to 4 they are for the connections of the different types of sensor.

Test and Communication terminals allow, respectively, to measure the current in the 4 - 20 mA loop, without opening it, and to communicate with the transmitter. To measure it, connect a multimeter in the mA scale in the "- " and "+ " TEST terminals. To communicate with it, use a HART configurator between "+ " and "- " COMM terminals. The wiring block has screws on which terminals type fork or ring can be fastened, see Figure. 1.3.

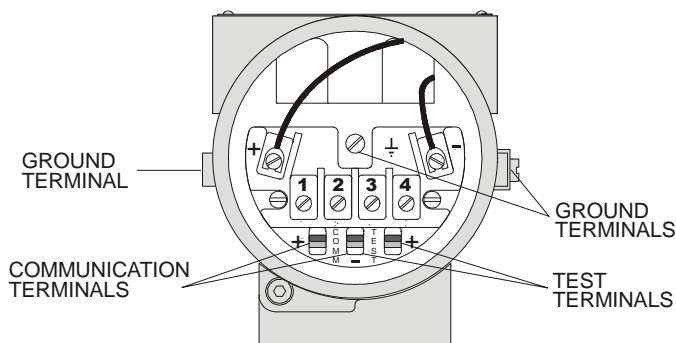

Figure 1.3 - Ground Terminal

The **TT301** is protected against reversed polarity.

For convenience there are three ground terminals: one inside the cover and two external, located close to the conduit entries.

Use of twisted pair (22 AWG) cables is recommended.

Avoid routing signal wiring close to power cables or switching equipment.

The Figure 1.3 shows the correct installation of the conduit, in order to avoid penetration of water, or other substance, which may cause malfunctioning of the equipment.

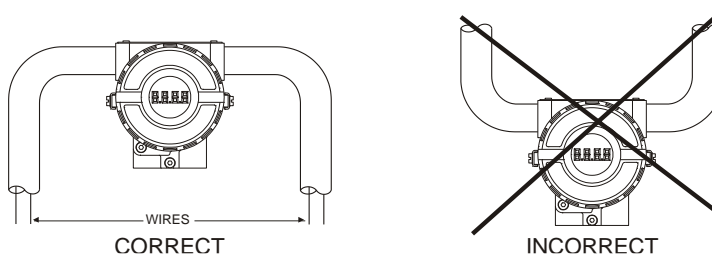

Figure 1.4 - Conduit Installation Diagram.

Loop Connections

WARNING

Do **not** connect the Power Supply to the sensor terminals (Terminals 1, 2, 3 and 4).

Connection of the **TT301** working as transmitter should be performed as in Figure 1.6.

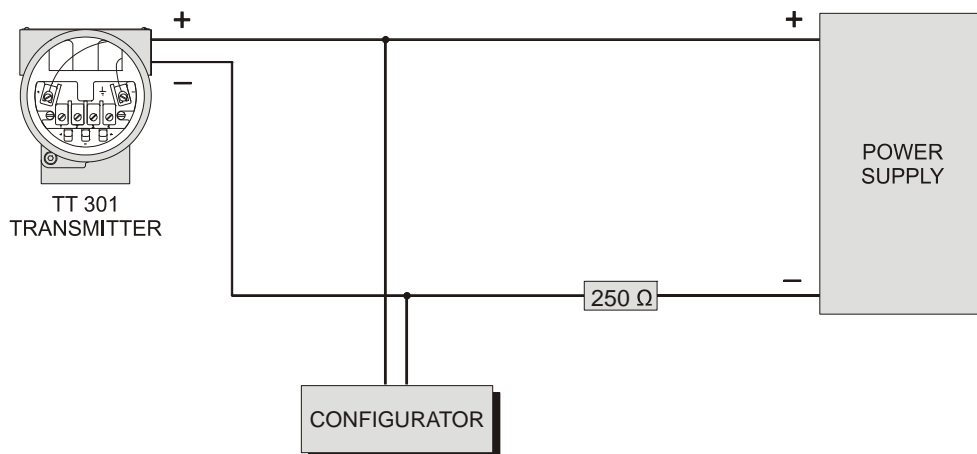

Figure 1.5 – Wiring Diagram for the TT301 Working as Transmitter

Connection of the **TT301** working as a controller (Optional) should be as indicated in Figure 1.5.

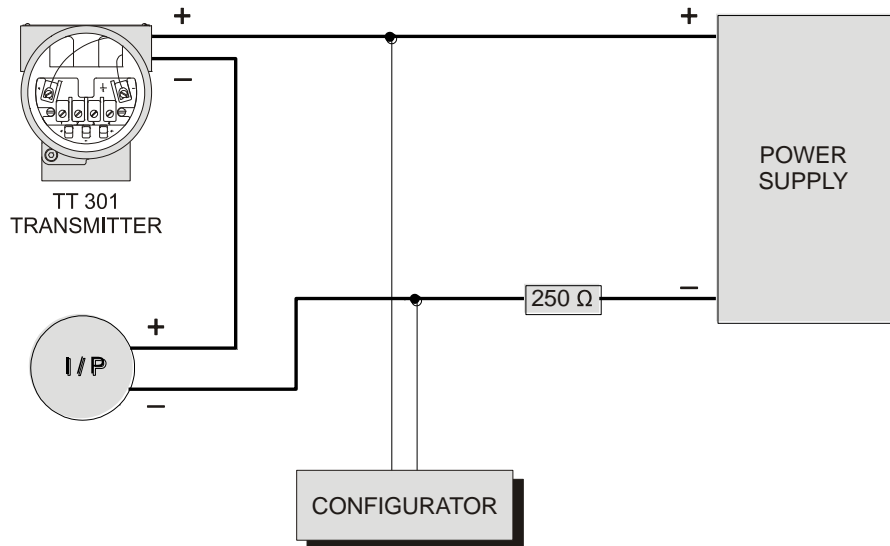

Figure 1.6 – Wiring Diagram for the TT301 Working as Controller

Connection of the **TT301** in multidrop configuration should be done as in Figure 1.6. Note that a maximum of 15 transmitters can be connected on the same line and that they should be connected in parallel. When many transmitters are connected to the same line, calculate the voltage drop through the 250 Ohm resistor and verify that the voltage of the power supply is enough (Figure 1.7).

Wiring diagram for the **TT301** in multidrop.

WARNING

For proper operation, the configurator requires a minimum load of 250 Ohm between it and the power supply.

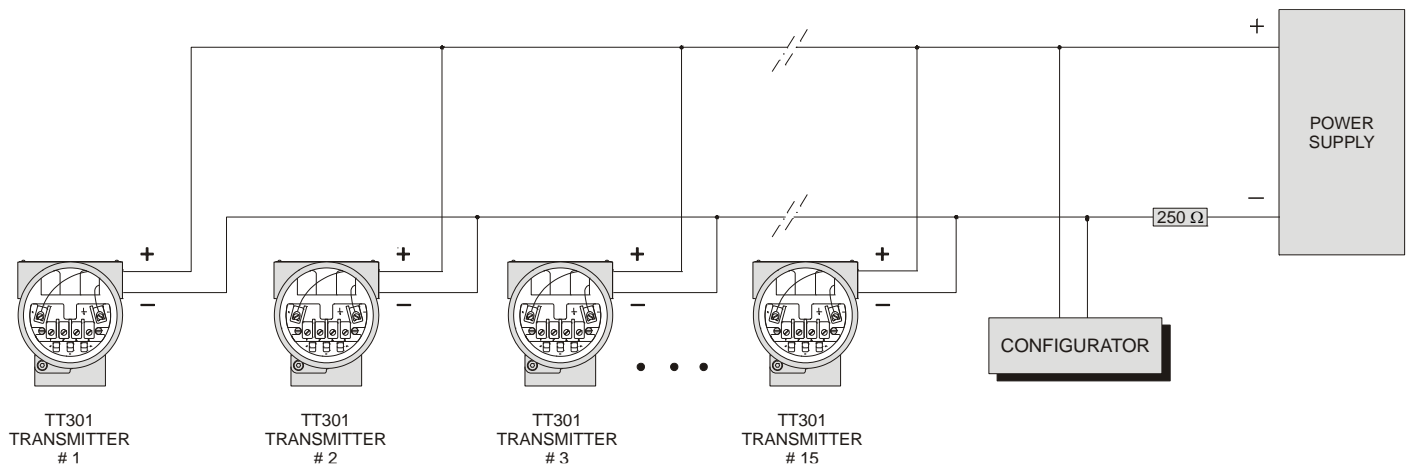

Figure 1.7 - Wiring Diagram for the TT301 in Multidrop Configuration

The Configurator can be connected to the communication terminals of the transmitter or at any point of the signal line by using the interface with alligator clips.

It is also recommended to ground the shield of shielded cables at only one end. The not grounded end must be carefully isolated.

NOTE

Make sure that the transmitter is operating within the operating area as shown on the load diagram (Figure 1.9). Communication requires a minimum load of 250 Ohm.

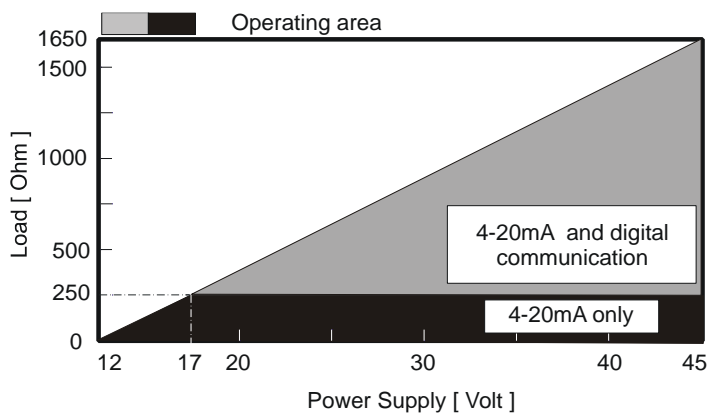

Figure 1.8 – Load Curve

The sensor should be connected as per Figure 1.8.

WARNING

When operating with two sensors, the sensors can not be both grounded. At least one has to be not grounded for proper operation of **TT301**.

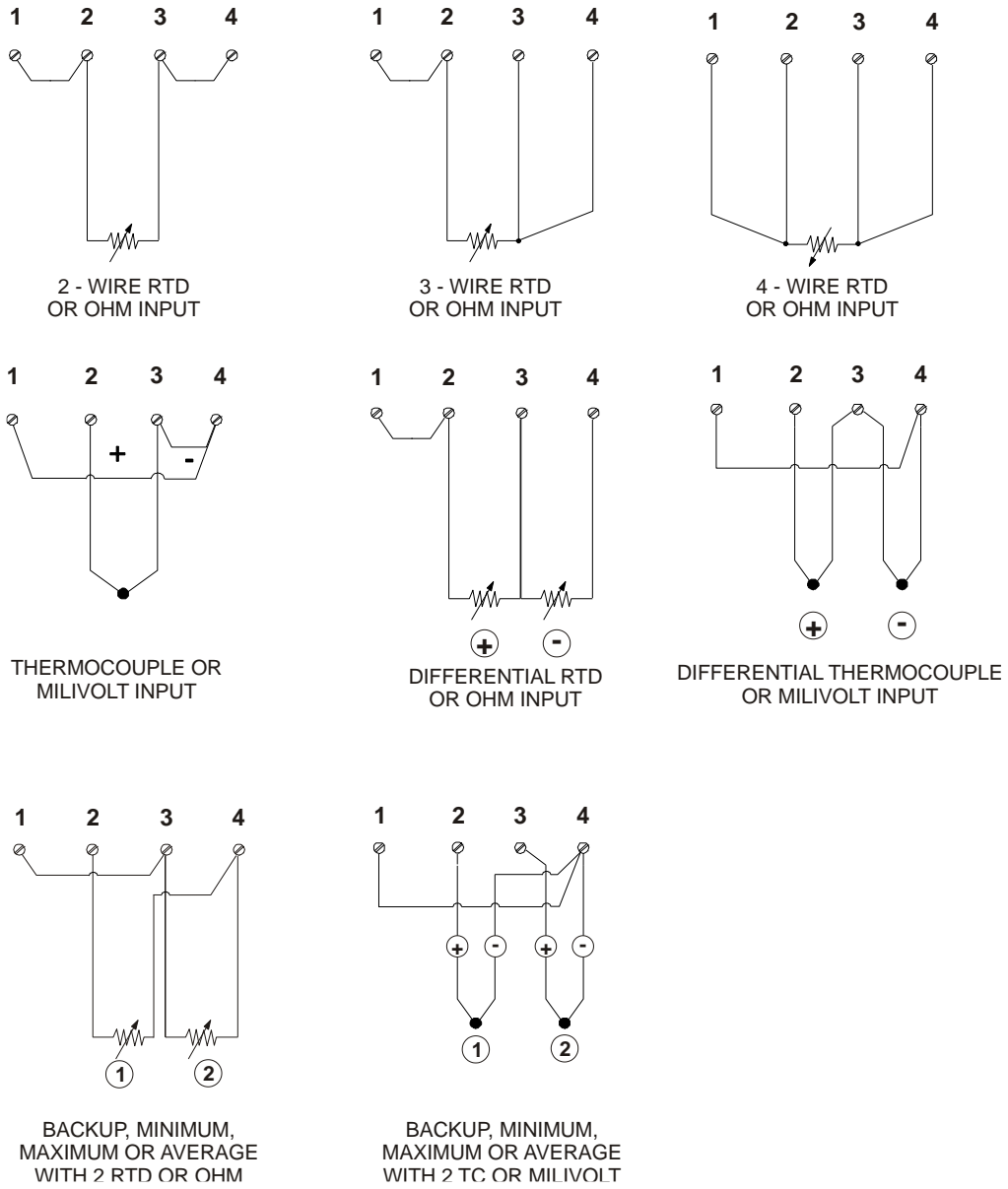

Figure 1.9 – Sensor Wiring

Installation in Hazardous Areas

Consult the Appendix A for Hazardous Location Approvals.

Section 2

OPERATION

The TT301 accepts signals from mV generators such as thermocouples or resistive sensors such as RTDs. The criterion is that the signal is within the range of the input. For mV, the range is -50 to 500 mV and for resistance, 0 to 2000 Ohm.

Functional Description-Hardware

Refer to the block diagram (Figure 2.1). The function of each block is described below.

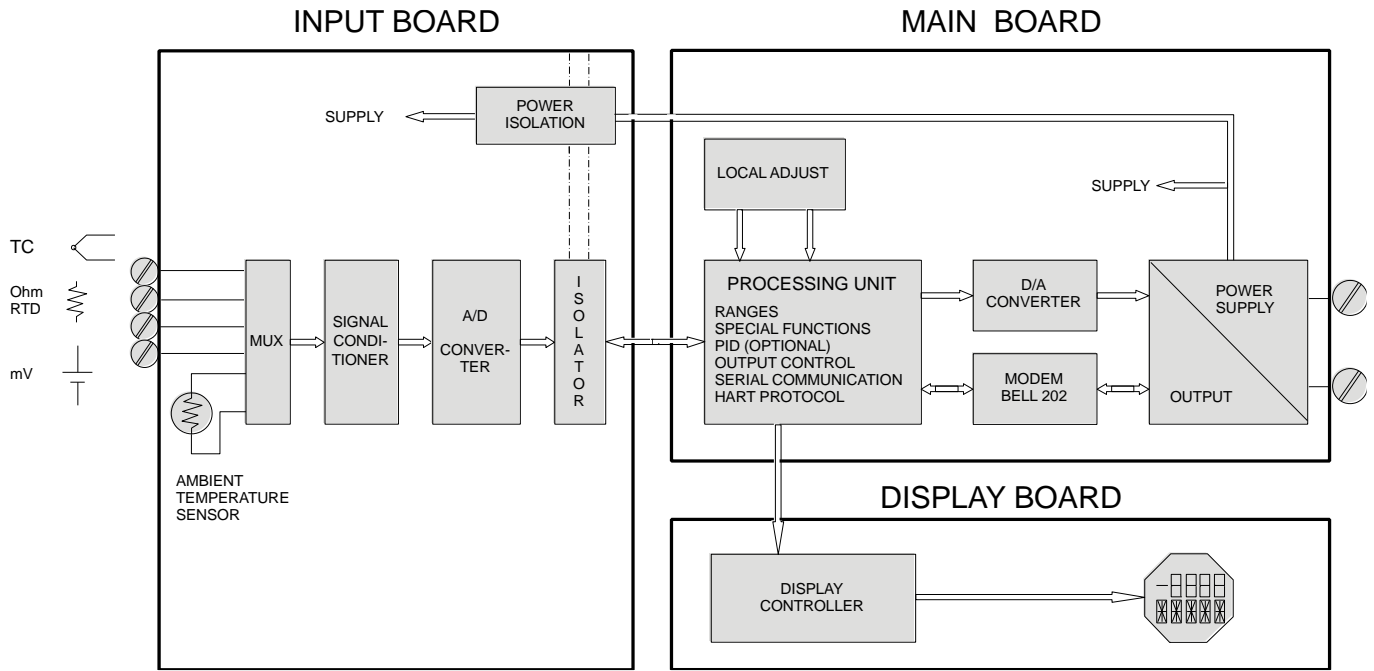

Figure 2.1 – TT301 Block Diagram

MUX-Multiplexer

The MUX multiplexes the sensor terminals to the signal conditioning section ensuring that the voltages are measured between the correct terminals.

Signal Conditioner

Its function is to apply the correct gain to the input signals to make them suit the A/D converter.

A/D Converter

The A/D converts the input signal to a digital format for the CPU.

Isolator

Its function is to isolate the control and data signal between the input and the CPU.

CPU - Central Processing Unit & PROM

The CPU is the intelligent portion of the transmitter, being responsible for the management and operation of all other blocks: linearization, cold junction compensation and communication. The program is stored in the PROM as well as the linearization data for the temperature sensors.

For temporary storage of data, the CPU has an internal RAM, the data in the RAM is lost if the power is switched off, however the CPU also has an internal nonvolatile EEPROM where data that must be retained is stored. Examples of such data are: calibration, configuration and identification data.

D/A Converter

Converts the digital data from the CPU to an analog signal with 14-bits resolution.

Output

Controls the current in the line feeding the transmitter. It acts as a variable resistive load whose value

depends on the voltage from the D/A converter.

Modem

Modulates a communication signal on the current line. A "1" is represented by 1200 Hz and a "0", by 2200 Hz. These signals are symmetric and do not affect the DC level of the 4-20 mA signal.

Power Supply

Power shall be supplied to the transmitter circuit using the signal line (2-wire system). The transmitter quiescent consumption is 3.6 mA; during the operation, consumption may be as high as 21 mA, depending on the measurement and sensor status.

The **TT301**, in the transmitter mode, shows failure indication at 3.6 mA if configured for low signal failure; at 21 mA, if configured for high signal failure; 3.8 mA in the case of low saturation; 20.5 mA in the case of high saturation and measurements proportional to the applied temperature in the range between 3.8 mA and 20,5 mA. 4 mA corresponds to 0% of the working range and 20 mA to 100 % of the working range.

Power Isolation

Its function is to isolate power supply between the input and the CPU.

Display Controller

Receives data from the CPU informing which segments of the Liquid Crystal Display, should be turned on.

Local Adjustment

Two switches that are magnetically activated. They can be activated by the magnetic tool without mechanical or electrical contact.

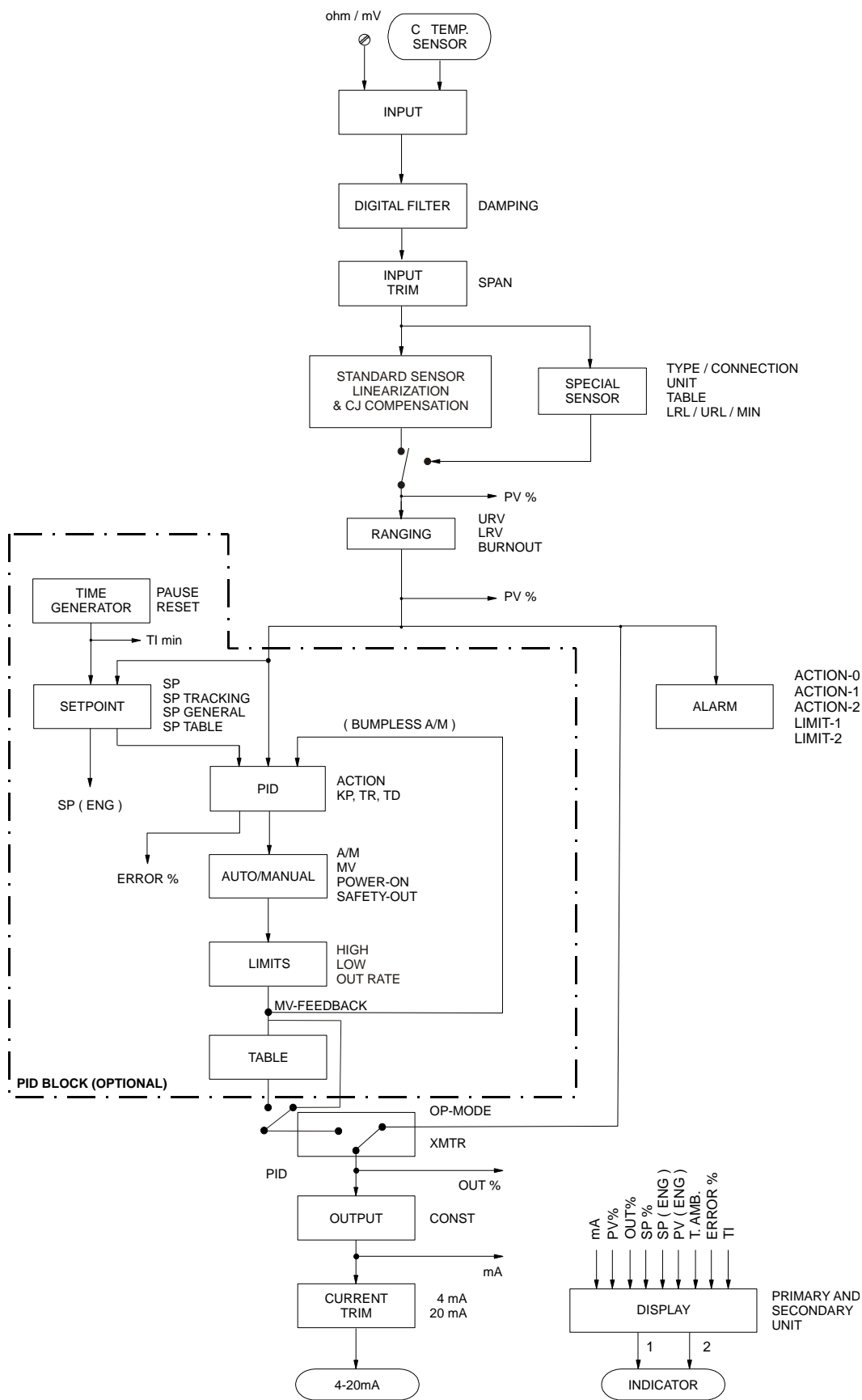

Figure 2.2 – Software Flow Chart

Functional Description - Software

Refer to the block diagram (Figure 2.2). The function of each block is described below.

Input

Calculates the actual mV or Ohm from the value sensed by the input circuitry.

Digital Filter

The digital filter is a low-pass filter with an adjustable time constant. It is used to smooth noisy signals. The Damping value is the time required for the output to reach 63.2% for a step input of 100%.

Input Trim

Here, the value obtained by READING-TRIM is used to correct the transmitter for long term drift.

Standard Sensor Linearization & Compensation

Here, the mV and Ohm measurements are linearized and cold-junction compensated according to the sensor characteristics stored in the CPU. The CPU contains data about most standard sensors available.

Ranging

It is used to set the process values corresponding to the output 4 and 20 mA in transmitter mode or process variable 0 and 100% in PID mode. In transmitter mode the LOWER-VALUE is the point corresponding to 4 mA, and UPPER-VALUE is the point corresponding to 20 mA. In PID mode, the LOWER-VALUE corresponds PV = 0% and UPPER-VALUE corresponds to PV = 100%.

Time Generator (Optional)

Counts the time to be used by the Setpoint generator function. It may be paused by using PAUSE or set to any value inside the table.

Setpoint (Optional)

Here, the setpoint is adjusted in PID. In this block, Setpoint tracking may be activated in SP-TRACK. The setpoint may also be generated automatically by turning the SP-GENERATOR on. When running, the setpoint generator will ramp and dwell the setpoint according to a table (recipe) configured in SP-TABLE.

PID (Optional)

First the error is calculated as SP-PV or PV-SP depending on which action (direct or reverse) is configured in ACTION. When Calendar Van Dussen function is used, the SP table points number is limited to 14 points instead to 16.

$$MV = Kp(e + \frac{1}{Tr} \int edt + Td \cdot \frac{dPV}{dt})$$

TABLE POINTS

This block relates the output (%) with the input (%) according to a 16 table points. The output is calculated through the interpolation of these points.

Auto/Manual (Optional)

The Auto/Manual mode is toggled in PID. In Manual, MV may be adjusted by the user in the INDIC option. The SP-POWER-ON option is used here to determine in which mode the controller should be upon powering it on.

Limits (Optional)

This block makes sure that the MV does not go beyond its minimum and maximum limits as established by the HIGH-LIMIT and LOW-LIMIT. It also makes sure that the Rate-of-Change does not exceed the value set in RATE-CHNG.

Output

Calculates the current proportional to the process variable or manipulated variable to be transmitted on the 4-20 mA output depending on the configuration in OP-MODE. This block also contains the constant current function configured in OUTPUT. The output is physically limited to 3.6 to 21 mA.

Current Trim

The 4 mA TRIM and 20 mA TRIM are used to make the transmitter current comply with a current standard, should a deviation arise.

Display

Alternates two indications as configured in DISPLAY. The engineering unit for the process variable can

be selected in UNIT.

Temperature Sensors

The **TT301**, as previously explained, accepts several types of sensors. The **TT301** is specially designed for temperature measurement using thermocouples or thermoresistances (RTDs).

Some basic concepts about these sensors are presented below.

Thermocouples

Thermocouples are the most widely used sensors in industrial temperature measurements.

Thermocouples consist of two wires made from different metals or alloys joined at one end, called measuring junction. The measuring junction should be placed at the point of measurement. The other end of the thermocouple is open and connected to the temperature transmitter. This point is called reference junction or cold junction.

For most applications, the Seebeck effect is sufficient to explain thermocouple behavior:

How the Thermocouple Works

When there is a temperature difference along a metal wire, a small electric potential, unique to every alloy, will occur. This phenomenon is called Seebeck effect.

When two wires of dissimilar metals are joined in one end, and left open in the other, a temperature difference between the two ends will result in a voltage since the potentials generated by the dissimilar materials are different and does not cancel each other out. Now, two important things must be noted. First: the voltage generated by the thermocouple is proportional to the difference between the measuring-junction and the cold junction temperatures. Therefore the temperature at the reference junction must be added to the temperature derived from the thermocouple output, in order to find the temperature measured. This is called cold junction compensation, and is done automatically by the **TT301**, which has a temperature sensor at the sensor terminals for this purpose. Secondly, if the thermocouple wires are not used all the way to the terminals of the transmitter (e.g. copper wire is used from sensor-head or marshalling box) new junctions with additional Seebeck effects will be created and ruin the measurement in most cases, since the cold-junction compensation will be done in the wrong point.

The relation between the measuring junction temperature and the generated millivoltage is tabulated in thermocouple calibration tables for standardized thermocouple types, the reference temperature being 0°C.

Standardized thermocouples which are commercially used, whose tables are stored in the memory of the **TT301**, are the following:

- ✓ **NBS (B, E, J, K, N, R, S, T)**
- ✓ **DIN (L, U)**
- ✓ **GOST (L)**
- ✓ **ASTM-E (W5Re/W26Re)**

Thermoresistances (RTDs)

Resistance Temperature Detectors, most commonly known as RTD's, are based on the principle that the resistance of a metal increases as its temperature increases.

Standardized RTDs, whose tables are stored in the memory of the **TT301**, are the following:

- ✓ **JIS [1604-81] (Pt50 & Pt100)**
- ✓ **IEC, DIN, JIS [1604-89] (Pt50, Pt100, Pt500, Pt1000)**
- ✓ **GE (Cu 10)**
- ✓ **Edison Curve (Ni 120)**
- ✓ **GOST (Pt50, Pt100, Cu50, Cu100)**
- ✓ **IEC 751-95 (Pt100)**
- ✓ **MILT (Ni120, Pt100)**

For a correct measurement of RTD temperature, it is necessary to eliminate the effect of the resistance of the wires connecting the sensor to the measuring circuit. In some industrial applications, these wires may be hundreds of meters long. This is particularly important at locations where the ambient temperature changes a lot.

The **TT301** permits a 2-wire connection which may cause measuring errors, depending on the length of connection wires and on the temperature to which they are exposed (see Figure 2.3).

In a 2-wire connection, the voltage V_2 is proportional to the RTD resistance plus the resistance of the wires.

$$V_2 = [RTD + 2x R] \times I$$

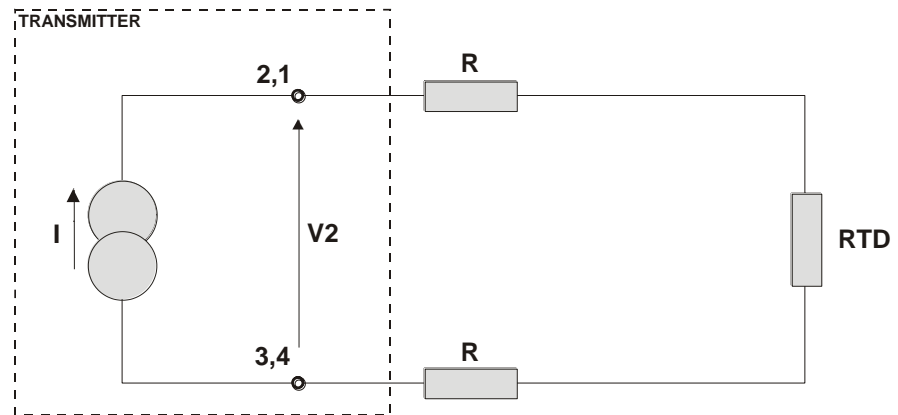

Figure 2.3 – Two-Wire Connection

In order to avoid the resistance effect of the connection wires, it is recommended to use a 3-wire connection (see Figure 2.4) or a 4-wire connection (see Figure 2.5).

In a 3-wire connection, terminal 3 is a high impedance input. Thus, no current flows through that wire and no voltage drop is caused. The voltage $V_2 - V_1$ is independent of the wire resistances since they will be canceled out, and is directly proportional to the RTD resistance alone.

$$V_2 - V_1 = [RTD + R] \times I - R \times I = RTD \times I$$

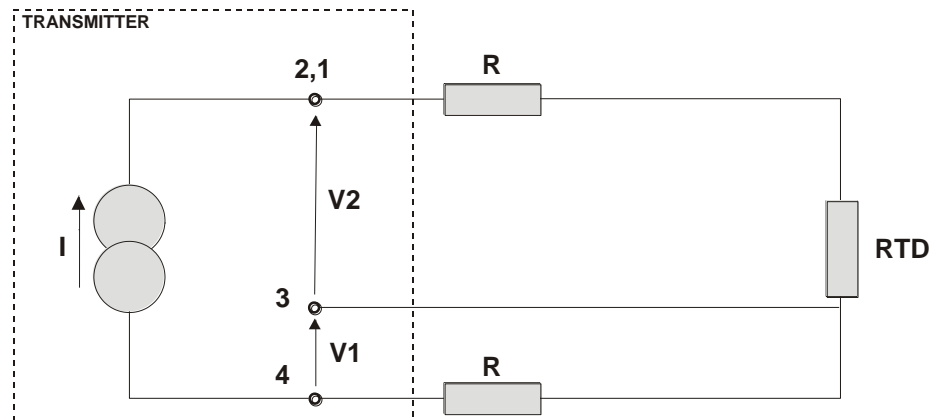

Figure 2.4 – Three-Wire Connection

In a 4-wire connection, terminals 2 and 3 are high impedance inputs. Thus, no current flows through those wires and no voltage drop is caused. The resistances of the other two wires are not interesting since no measurement is done on them. Hence the voltage V_2 is directly proportional to the RTD resistance. ($V_2 = RTD \times I$).

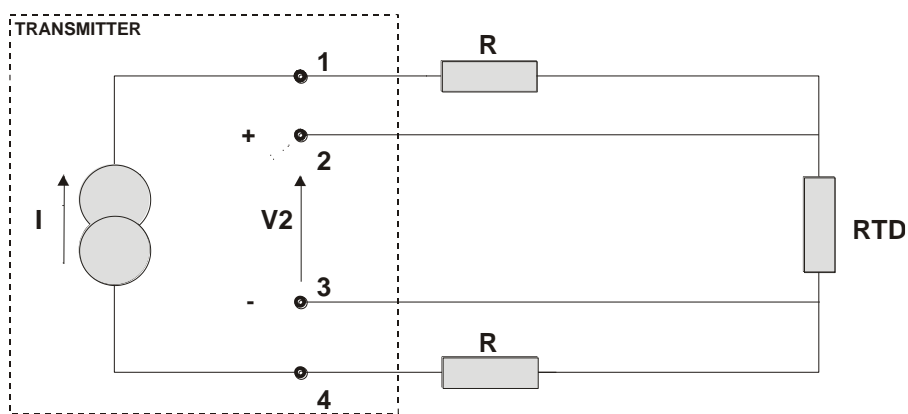

Figure 2.5 – Four-Wire Connection

A differential connection is similar to the two-wire connection and gives the same problem (see Figure 2.6). Terminal 3 is a high impedance input. Thus, no current flow through and no voltage drop is caused, but the resistance of the other two wires will be measured and does not cancel each other out in a temperature measurement, since linearization will affect them differently.

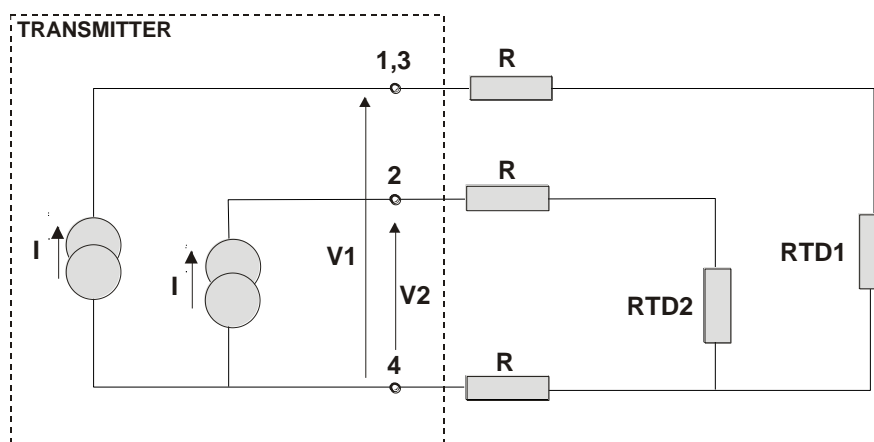

Figure 2.6 – Differential Connection

NOTE

The material, the gauge, and the length should be the same connections of 3 or 4 threads.

The Display

The digital indicator is able to display one or two variables which are user selectable. When two variables are chosen, the display will alternate between the two with an interval of 3 seconds.

The different fields and status indicators are explained in Figure 2.7.

Monitoring

During normal operation, the **TT301** is in the monitoring mode. In this mode, indication alternates between the primary and secondary variable as configured in **DISPLAY**. See Figure 2.8.

The display indicates engineering units, values and parameters simultaneously with most status indicators. The monitoring mode is interrupted in two situations:

- ✓ User performs complete local adjustment.
- ✓ An alarm is activated.

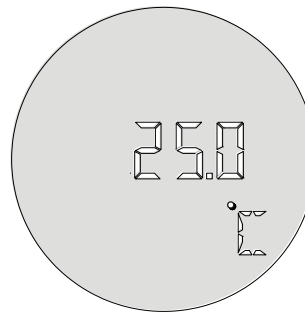

Figure 2.7 – Display

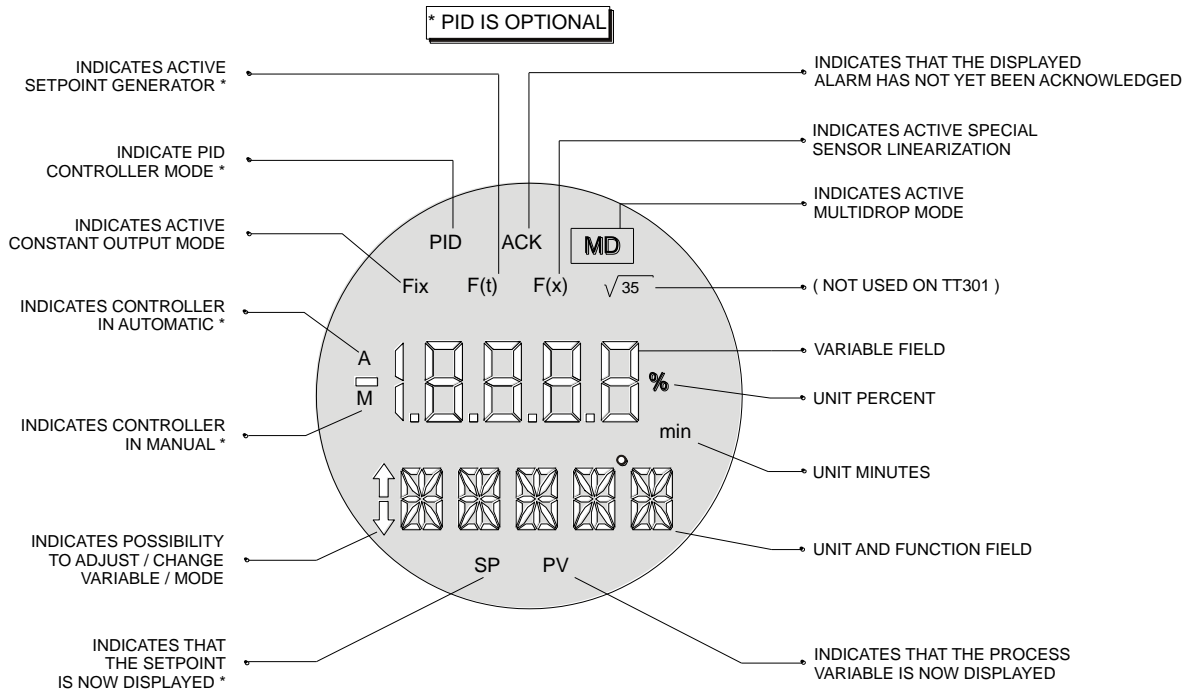

Figure 2.8 – Typical Monitoring Mode Display

Alarm

The two alarms are software alarms and have no contacts available on the transmitter. The alarms are acknowledged by using the Local Adjustment or the Configurator, which can view and configure alarms as well - see further Section III. During an alarm, the display will indicate which alarm has been activated and if it has been acknowledged or not.

The transmitter display also indicates the alarms status as shown in Figure 2.9.

AL H means High Alarm, AL L means Low Alarm and ALO indicates Burnout failure. The ACK indicates that the alarm has not yet been acknowledged.

When the alarm condition disappears, the "ACK" is switched off and the display returns to monitoring mode.

For further information on alarm configuration, see Section III - Programming Using Terminal.

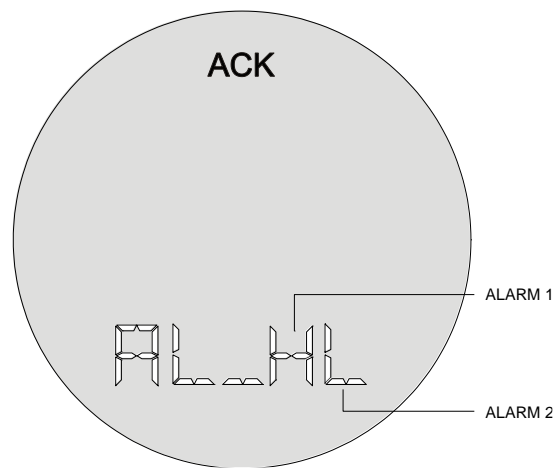

Figure 2.9 – Typical Alarm Condition Display

CONFIGURATION

The Temperature Intelligent Transmitter **TT301** is a digital device bearing the most advanced features a measurement apparatus can offer. A HART® digital communication protocol permits the device to be connected to an external computer for a simple and complete configuration. These computers, connected to the transmitters, are called HOST computers and may be a Primary or Secondary Master type. Although HART may be a master/slave protocol, it may coexist with up to two masters in a field bus. Generally, the Primary HOST stands for a Supervisory and the Secondary HOST is used as a Configurator.

Transmitters, on the other hand, may be connected to a point-to-point or a multi-drop network. In a point-to-point network, the equipment should have its address set at “0”, so that the output current is modulated from 4 to 20 mA, according to the measurement performed. In a multidrop network, the transmitters should be configured on a network address between “1” and “15”, if the identification devices work via address. In this case, the transmitter’s output current must be constant, each transmitter consuming 4 mA. If the identification mechanism is done via Tag, the transmitters may be addressed at “0” and control their current output, even on a multidrop configuration.

The **TT301** may be configured both for Transmitter and Controller and the HART addressing may be used as follows:

- ✓ **TRANSMITTER MODE:** The **TT301** controls the current output, while the “1” to “15” addresses adjust the TT301 on multidrop mode setting the output current control on 4 mA.
- ✓ **CONTROLLER MODE:** The **TT301** always controls the output current according to the value calculated for the Manipulated Variable, regardless of its address value on the net.

NOTE	
When configured in multidrop for the classified areas the entity parameters allowed for the area must be strictly observed. So, verify that:	
$C_a \geq \sum C_{ij} + C_c$ $L_a \geq \sum L_{ij} + L_c$	
$V_{oc} \leq \min [V_{maxj}]$ $I_{sc} \leq \min [I_{maxj}]$	
Where:	
C_a, L_a	= capacitance and inductance permitted in bus;
C_{ij}, L_{ij}	= transmitter capacitance and inductance r j (j=1, 155), without internal protection;
C_c, L_c	= cable capacitance and inductance;
V_{oc}	= open circuit tension of the intrinsic safety barrier;
I_{sc}	= short circuit tension of the intrinsic safety barrier;
V_{max}	= maximum permissible tension to be applied on the r j transmitter;
I_{max}	= maximum permissible tension to be applied on the r j transmitter.

The **TT301** Intelligent Temperature Transmitter presents a comprehensive set of HART Commands that permit accessing any implemented functionality. These commands comply with the HART protocol specifications and are grouped in Universal Commands, Common Practice Commands and Specific Commands.

Smar developed the **CONF401** and **HPC301** software, the first one works in Windows platform (**95, 98, 2000, XP and NT**) and **UNIX**. The second one, HPC301, works in the most recent technology in PDA’s. They bring easy configuration and monitoring of field devices, capacity to analyze data and to modify the action of these devices. **The operation characteristics and use of each one of the configurators are stated on their respective manuals.**

Figures 3.1 and 3.2 show the front of the Palm and the CONF401 screen, with the active configuration.

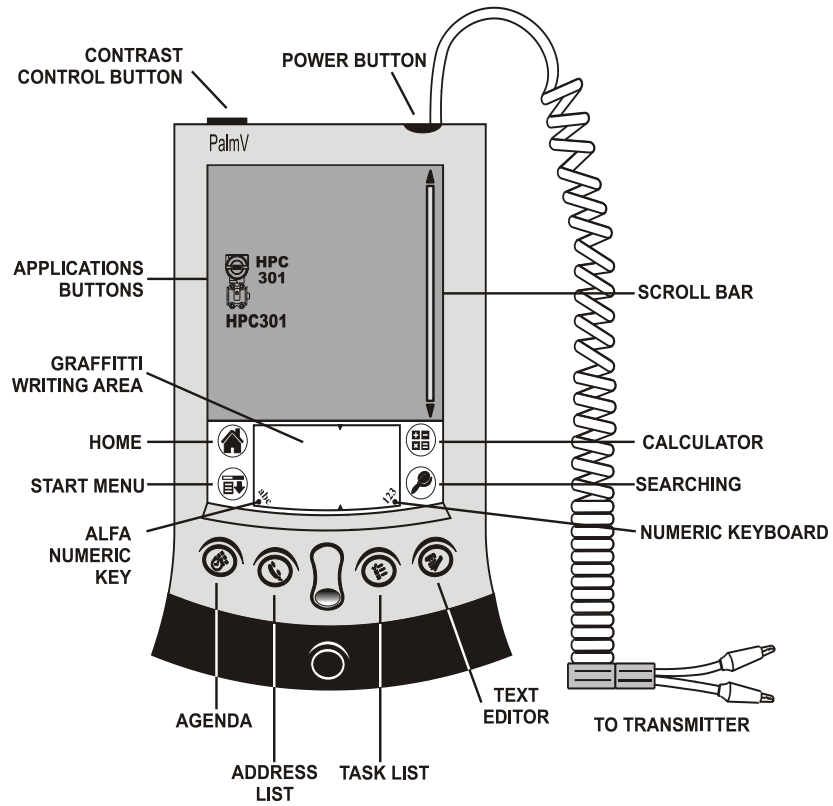

Figure 3.1 - Configurator

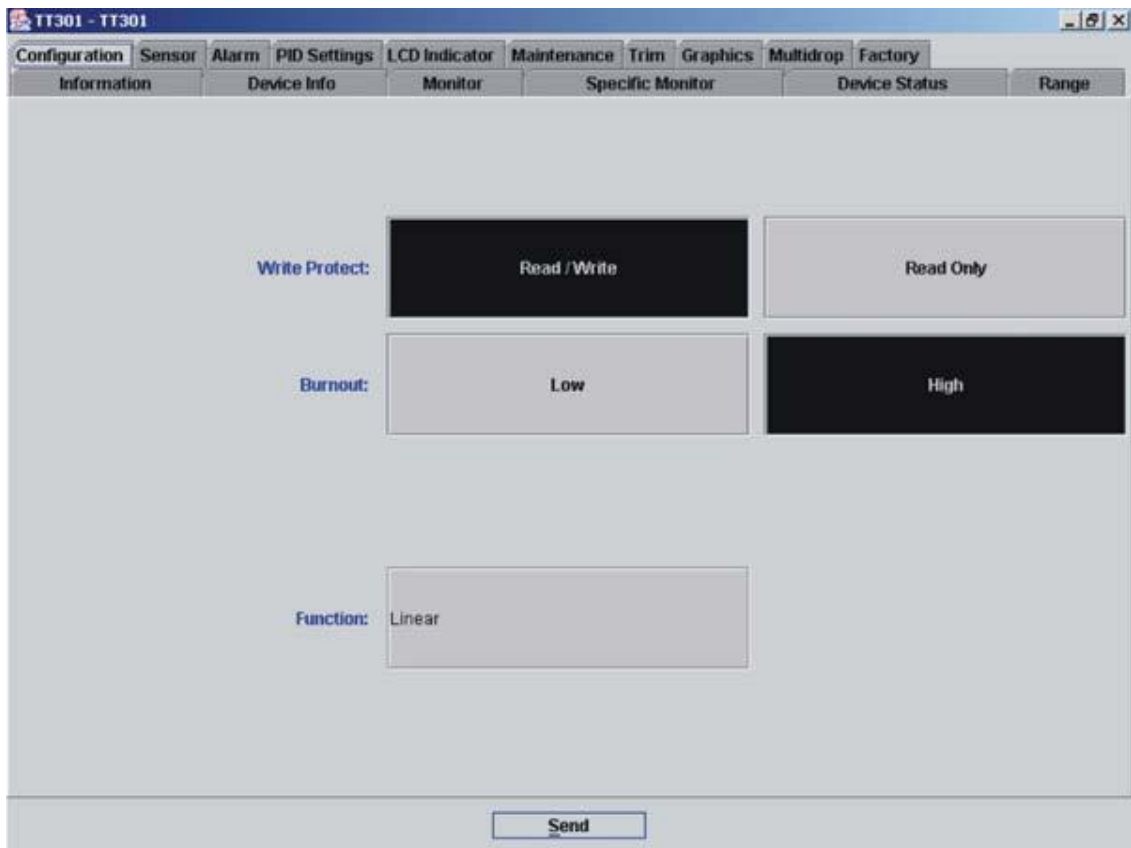

Figure 3.2 – CONF401 Screen

Configuration Resources

Through the HART configurators, the **TT301** firmware allows the following configuration resources to be accessed:

- ✓ Transmitter Identification and Manufacturer Data;
- ✓ Primary Variable Trim – Temperature;
- ✓ Secondary Variable Trim – Terminal Temperature;
- ✓ Equipment Current Trim;
- ✓ Transmitter Adjustment to Work range;
- ✓ Engineering Unit Selection;
- ✓ Set Point Generator Configuration;
- ✓ PID Controller Configuration;
- ✓ Equipment Configuration;
- ✓ Equipment Maintenance.

The operations occurring between the configurator and the transmitter do not interrupt the temperature measuring and do not disturb the output signal. The configurator may be connected on the same 4-20 mA signal cable to a maximum 2000 m distance from the transmitter.

Programming Tree

The programming tree is a structure resembling a tree, with all the resources available in the software, as shown on Figure 3.3.

DEVICE ADDRESS 0: Used when the Configurator is connected in parallel with a single transmitter and this transmitter has 0 (zero) for address.

FROM: 0 TO 15: Used when the Configurator is connected in parallel with up to 15 several transmitters and these transmitters are configured with different addresses (See Multidrop).

WARNING

All transmitters are factory-configured without passwords. To avoid faulty operation on a few critical levels on the programming tree, the configuration is recommended of all passwords before operating. See option "PASSWORD", on the maintenance section.

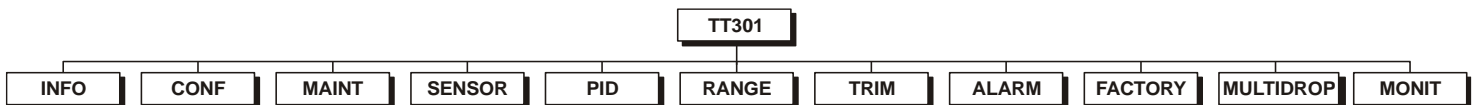

Figure 3.3 – Configuration Tree

INFO – The main information on the transmitter may be accessed here. They include: Tag, Description, Message and Single ID.

CONF – This option permits Burnout and Display configurations

MAINT – This option tests the current loop, resets the operations equipment, sees the operations counter and configures the password levels and ordering code.

SENSOR – This option permits configurate the sensor type and the connection to be used.

PID – This option connects and disconnects the programming function and adjusts and monitors all of the control parameters.

MONIT – The user may monitor 4 of the transmitter dynamic variables and the current output.

RANGE – The following outputs related to the parameters may be configured: Lower Value, Upper Value, Unit and damping.

TRIM – Adjusts the transmitter displaying to a current or an Ohm/mV standard.

ALARM – Any of the three available types of alarm may be configured. They may be used as an alert tool to be activated when the PV is out the configured range.

FACTORY – Contains all parameters pre-configured at plant. This procedure is in-factory performed and may not be adjusted by the user.

MULTIDROP – The user may track the equipments connected to the loop, thus detecting their respective addresses. Also, an address is designated to each device to be connected to the network.

Identification and Manufacturing Data – Info

The main information on the transmitter may be obtained here. They are: Tag, Description, Message, Date and Single Identification. There is also a screen with important additional information on the equipment. They are: Manufacturer, Type of equipment, Serial Number and Transmitter Firmware Version, HART protocol Version and Hardware Revision.

The following information are available for the **TT301** transmitter identification and manufacturer data:

- ✓ **TAG** – Field with 8 alphanumerical characters for transmitter identification;
- ✓ **DESCRIPTION** – Field with 16 alphanumerical characters for additional transmitter identification;
- ✓ **MESSAGE** – Field with 32 alphanumerical characters for any other information, such as the name of the last person to calibrate, some special caution to be observed or if a ladder is needed to access the transmitter, for example.
- ✓ **MODIFICATION DATE** – The date may be used to identify a relevant date, as the last calibration, the next calibration or installation. The date is stored in the form of bytes, where DD = [1,..31], MM = [1..12], AA = [0..255] and the effective year is calculated by [year = 1900 + AA];
- ✓ **UNIQUE ID*** - Information for reading only.

*NOTE
This item may not be modified.

Configurator - Conf

This function affects the transmitter 4-20 mA output and display reading. It may alter the lower and upper burnout, select the variables to be displayed and verify the status of writing protection.

Burnout – The burnout may occur when the sensor reading is out of range or the sensor is open. In this case, the transmitter may be adjusted for maximum output limit at 21 mA, by configuring it on the upper value, or the minimum limit at 3.6 mA configured on the lower value.

Calibration – Range

The Lower and the Upper Values are calibrated in this operational range, which also selects the unit representing the process variable and the transmitter damping.

Maintenance - Maint

The maintenance option offers the user 5 choices to check his loop functionality, such as: restart the equipment, test the current loop, verify the number of configurations performed, configure passwords and verify the equipment order code. Below is a brief description of the characteristics performed by the equipment Maintenance function:

Device Reset – The equipment is switched off and then on. The restarting option should be carried out as a last resort, as it may destabilize the process control.

Loop Test – The current output may be adjusted to any desired value between 3.8 and 21.0 mA regardless of the input value. There are a few stable current values for the loop test. The options available are: 4, 8, 16 or 20 mA.

Operation Counter: The operation number counting is useful to indicate if somebody altered any configuration on the equipment. Every time one of the parameters below is altered, the respective alteration counter is activated. The monitored parameters are:

- Range configuration (Lower/Upper)
- Change to Constant Current
- 4 mA Trim
- 20 mA Trim
- Sensor Trim

- Burnout configuration
- Sensor configuration
- Auto/Manual shift (PID enabled)
- Multidrop

Passwords: The options for password configuration and access level are: Info, Trim, Conf, Maint, PID and Alarm.

There are three password levels. They are used to restrict the access to certain operations in the programming tree. In the default condition no password is configured.

Each operation item may have a specified password level. The default password level is 0 ("Zero"), but the adjustment of **Info** at level "1" and **Maint** at level "3" are feasible. These levels may be altered by someone who knows the level "3" password. To cancel, just delete the current password and send another blank one.

The level 3 password is hierarquically superior to the level 2 passwords, which, on its turn is superior to level 1.

Ordering code – It contains the equipment ordering code.

NOTE
Contact Smar in case you forgot or lost your password.

Sensor Types - Sensor

It configures the **TT301** input for the type of sensor in use and its connecting mode. The types covered in this manual are:

RTD: Temperature Resistant Detector

Cu10 (GE)
 Ni120 (Edison Curve #7)
 Pt50, 100, 500, 1000 (IEC)
 Pt50, 100 (JIS)
 Pt50, PT100, Cu50, Cu100 (GOST)
 Pt100 (IEC 751-95)
 Ni120, Pt100 (MILT)
 Configurable for 2, 3 or 4 wires, differential, backup, maximum, minimum or average

TC: Thermocouples

B, E, J, K, N, R, S e T (NBS)
 L e U (DIN), K e S (IEC584)
 L (GOST)
 W5Re/W26Re (ASTM)
 Configurable for 2, 3 or 4 wires, differential, backup, maximum, minimum or average

Ohm: Resistance Measuring

0 a 100 Ohm
 0 a 400 Ohm
 0 a 2000 Ohm
 Configurable for 2, 3 or 4 wires, differential, backup, maximum, minimum or average

mV: Voltage Measuring

-6 a 22 mV
 -10 a 100 mV
 -50 a 500 mV
 Configurable for 2 wires, differential, backup, maximum, minimum or average

Special: Special Sensor

Special Ohm
 Special mV

It is used for special sensors like charge cells or position resistive indicators. This resource may turn the **TT301** into a mass, volume, position, etc. transmitter.

Cold Junction:

This option enables or not the cold junction for TC sensors. Do not use the "send" button. The alteration is made automatically in the transmitter.

Conection and Work Model

After the selection of the sensor type is necessary to choose the way how sensors work. The available options are: differential, 2 wires, 3 wires, 4 wires, backup, average, maximum and minimum. In the options 2, 3 or 4 wires, only one sensor is connected in the device terminal. In the options differential, backup, average, maximum and minimum are connected 2 sensors.

2, 3 and 4 wires: only one sensor will go to generate the process variable. If it ruptures, the burnout indication will be showed.

Differential: In this mode, the **TT301** will go to work with the measure difference between the sensors. If one of them to ruptures, the burnout indication will be showed.

Backup: TT301 works with the reading of the first sensor (between 2 and 4 terminals). If this sensor brokes, the second sensor (between 3 and 4 terminals) will replace it and show the process variable reading. In this case, the reading of the first sensor will be discarded, even if this sensor returns to operate again. The first sensor will back to operate again if either gives it a reset by software or reenergize the device again. The message "S1BAD" will appear on LCD and the HART response code "Non-PV out of limits" is set. In case of failure of the second sensor, the transmitter will continue to operate normally but the message "S2BAD" will appear on LCD and the HART response code "Non-PV out of limits" will be set.

Average: the final reading will be the average of the signals from two sensors. If the difference between them is higher than a programmed value, an alarm will be generated. If one of them ruptures, the other continues performing the process variable reading, and an alarm will be generated to inform this situation. The message "S1BAD" or "S2BAD" will appear on LCD and the HART response code "Non-PV out of limits" will be set.

Maximum and minimum: the process variable will be supplied by sensor that has either maximum or minimum reading, respectively. If one of them ruptures, the other continues performing the process variable reading, and an alarm will be generate to inform this situation. The message "S1BAD" or "S2BAD" will appear on LCD and the HART response code "Non-PV out of limits" will be set.

Special Sensor Configuration

The special sensor is a function that permits sensors whose typical curves are not stored in the **TT301** memory to be used or linearized. Table 3.1 shows the available units for special sensors.

Any sensor may be used, provided the **TT301** accepts the signal range generated by the sensor. The Ohm and mV sensors limitations may be seen on table 3.2.

To change the special sensor configuration select **special** on the **sensor** menu.

VARIABLE	UNITS
Pressure	inH ₂ O, InHg, ftH ₂ O, mmH ₂ O, mmHg, psi, bar, mbar, g/cm ² , Pa, KPa, Ton, ATM
Volume Flow	ft ³ /min, gal/min, l/minin, Gal/min, m ³ /h, gal/s, l/s, Ml/d. ft ³ /s, ft ³ /d, m ³ /s, m ³ /d, Gal/h, Gal/d, ft ³ /h, m ³ /min, bbl/s, bbl/min, bbl/h, bbl/d, gal/h, Gal/s, l/h
Speed	ft/s, m/s, m/h
Temperature	°C, °F, °R, K
Voltage	mV, v
Volume	gal, l, Gal, m ³ , bbl, bush, Yd ³ , ft ³ , ln ³
Level & Length	ft, m, in, cm, mm
Time	min, sec, h, dia
Weight (Mass)	gram, Kg, Ton, lb, Shton, LTon
Mass Flow	g/s, g/min, g/h, kg/s, kg/min, kg/h, kg/d, Ton/min, Ton/h, Ton/d, lb/s, lb/min, lb/h, lb/d, Ton/d
Temperature	SGU, g/cm ³ , kg/m ³ , g/ml, kg/l, g/l, TWARD, BRIX, Baum H, Baum L, API, % Solw, % Solv, Ball
Others	Ohm, Hz, mA, %, pH, μs, cPo
Special	5 characters

Table 3.1 – Special Sensor Available Units

The sensor typical curve may be scheduled on the **TT301** EEPROM memory as a 16-point table. These tables are usually supplied by the sensor manufacturer, but may also be obtained at a lab test.

WARNING	
The special sensor function may not be used when the setpoint generating function is being used and vice-versa.	

The options for configuring the special sensor are:

Range – For the Ohm sensor there are 3 ranges: 0 to 100, 0 to 400 and 0 to 2000 ohm. For the mV sensor there are also 3 ranges: -6 to 22, -10 to 100 and -50 to 500.

Connection – There are 4 options: differential, two wires, three wires and four wires.

X and Y Tables – The special sensor table points are inserted here. The sensor input is stored as an X-variable. The chosen output is stored as a Y-variable (19999 ≤ Y ≤ +19999). The X-input should always have growing values.

X = Ohm or mV terminal block input.

Y = Chosen output in engineering units.

Watch the following limitations for the X variable values:

CONNECTION TYPE	2, 3 OR 4 WIRES	DIFFERENTIAL (each input)
Ohm	0 < X < 2000	0 < X < 1000
mV	-6 < X < 500	10 < X < 250

Table 3.2 – Special Sensor Input Range

V.INF Calibration range lower limit. The least possible value for transmitter calibration when using this special sensor.

V.SUP Calibration range upper limit. The most possible value for transmitter calibration when using this special sensor.

Minimum Span The least possible span for transmitter calibration when using this special sensor.

Unit – Engineering Unit to be associated to the measured variable. If one from most of 100 units is selected, the respective HART protocol code will be attributed to this parameter. This way, the whole supervisory system having HART protocol may access the **Unit** menu.

PID

This option adjusts the PID parameters including the Setpoint, change on auto/manual mode and the tuning parameters.

The **TT301** with an activated PID works as a controller/transmitter, while, deactivated, it works only as a transmitter

The transmitter 4/20mA output may become a PID controller output, following the equation below:

$$MV = Kp \left(e + \frac{1}{Tr} \int edt + Td \cdot \frac{dPV}{dt} \right)$$

Where:

e = PV – SP (Direct) or SP – PV (Reverse)

SP = Setpoint

PV = Process Variable

Kp = Proportional Gain

Td = Derivative Time

MV = Output

Tr = Integration Time

See below a list of configurations feasible on the PID function.

PID Controller – ON/OFF

Tuning Parameters – This feature configures the Kp, Tr and Td tuning parameters, as well as output limits and rate.

PV, SP, MV and Error Readings – Provides real-time variable value.

SP Tracking – When in MANUAL, the setpoint follows the PV. When the controller is switched to AUTO, the last PV value before the switch will be regarded as SP.

Control Action – This option configures the transmitter Operation Mode. The options are:

Direct – The output increases when the PV rises.

Reverse – The output decreases when the PV does.

Control Mode – Selects Automatic and Manual.

MV Configuration – Adjusts the manipulated variable.

SP Configuration – The Setpoint is adjusted.

Control Limits – This option switches the **SP Power On** to automatic, manual and last value.

Safety value – The output after a power shortage or during a failure.

Rate / Alteration – The maximum allowed output change.

Lower Limit – The minimum allowed percent output.

Upper Limit – The maximum allowed percent output.

Setpoint Table – When the setpoint generator is activated, the setpoint varies according to a curve table. The time is always read in minutes and the setpoint in percentage.

SP Generator – When activated, the setpoint varies with time according to the schedule on TABELA_SP table.

Monitoring - MONIT

This function monitors the transmitter 4 dynamic variables and the output current on the configurator display simultaneously.

VARIABLE	DESCRIPTION
CORRENTE	mA output.
*MV	Output percent.
PV	Process variable on the selected engineering unit.
TEMP	°C Room temperature.
PV%	Process variable percent.
*SP%	Setpoint percent.
*SP	Setpoint on the selected engineering unit.
*TIME	Setpoint generator time in minutes.
*ER%	Deviation between SP and PV percents.

Table 3.3 - Monitored Variables

The indications will always oscillate between the first and the second variable.

*NOTE
These items may only be selected on PID mode.

EXAMPLE
Set the first variable indication for PV percent and the second variable for current.

If the display should not indicate the oscillation, select the same indication in both variables, or select "SEM" ("without") on the second variable.

Calibrating the TT301

A transmitter calibration consists of configuring the input values related to 4 mA and 20 mA. The **TT301** may do this in 4 different methods:

- 1 – By using the Configurator (no-reference method) whose calibration input is not required.
- 2 – By using the Configurator and an input signal as reference (referenced method).
- 3 – Local adjustment and an input signal as reference (simple local adjustment, with reference).
- 4 – Local adjustment and an input signal as reference (complete local adjustment, with reference).
- 5 – Local adjustment (complete local adjustment, without reference).

In transmitter mode, the lower value always corresponds to 4 mA and the upper value to 20 mA. In PID mode, the lower value corresponds to PV=0 % and upper value to PV=100 %.

Calibration Without Reference

The **TT301** may be configured to supply 4 to 20 mA, the equivalent to the temperature limits on the user's application, without the need to connecting a reference calibrating generator on its terminals. This is possible because the **TT301** has linearization curves for several standard temperature sensors in its memory. Let us suppose the transmitter range is calibrated from -100 to 300°C and one must calibrate it on 0 to 100°C .

The transmitter generates a signal varying from 4 to 20 mA when the temperature oscillates between 0 and 100°C .

Watch that both the LOWER and UPPER values are entirely independent. Adjusting one does not affect the other. However, the following rule must be observed:

- a) Both values should not be less than the lower limit or in excess of the upper calibration limit.
- b) The Upper value less Lower value span must be larger than the LOWER SPAN.

If a signal needs to be reverted, i.e., have an UPPER VALUE smaller than the LOWER VALUE, proceed as follows:

Make the inferior value as close as possible to the Superior Value or vice-versa, observing the allowed minimum span. Adjust the Superior Value with the desire value and, then, adjust the Inferior value.

Example: If the transmitter is calibration such as:

LOWER VALUE = 4 mA = 0°C

UPPER VALUE = 20 mA = 100°C and the values should change to:

LOWER VALUE = 4 mA = 100°C

UPPER VALUE = 20 mA = 0°C ;

Considering that the Pt100 IEC Minimum Span is 10°C , the adjustments must be altered as follows:

- a) LOWER VALUE = 90, or 100-10.
- b) UPPER VALUE = 0°C
- c) LOWER VALUE = 100°C

The table 3.4 shows graphycaly how to do this ranging.

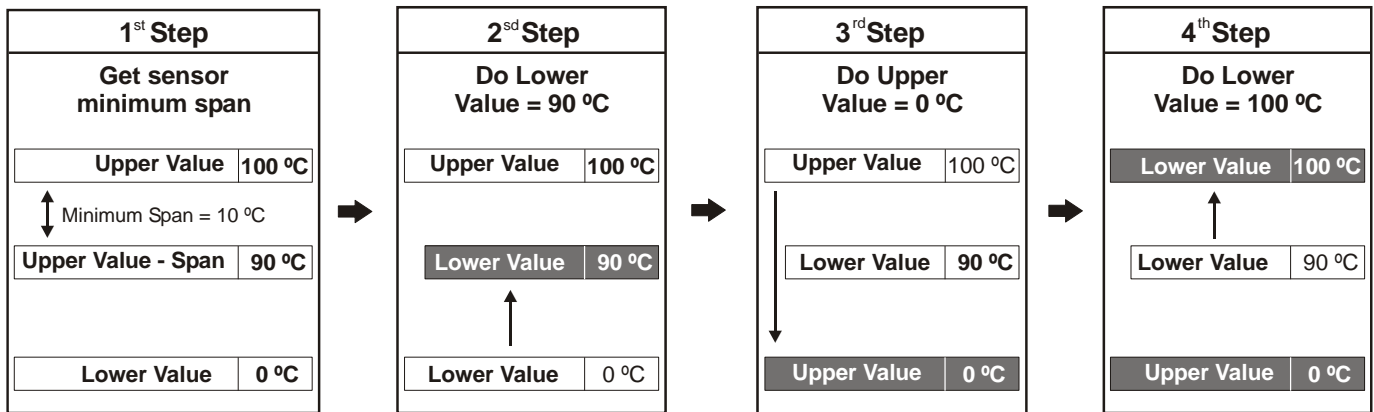

Table – 3.4 – Procedure to Range without Reference

Calibration With Reference

This is the most convenient way to calibrate a transmitter. Apply the signal for adjusting the 4 mA point (PV=0 %). The Lower Value is altered but the span remains the same.

The same procedure is applied for the Upper Value.

LOWER VALUE = 0 Ohm
 UPPER VALUE = 100 Ohm

Example: When measuring resistance the **TT301** is calibrated as follows:

After the installation is done, the potentiometer (input sensor) was found to have a 5 Ohm residual resistance when its indicator was on a zero position.

The Lower Value reference trim quickly corrects this problem, causing the Lower Value to equal 5 Ohm.

The Upper Value may be altered in the same way.

As mentioned before, the Ohm or mV sensor input may differ a little from its plant standard.

The Zero and Gain Trim may be used to adjust the transmitter reading to Engineering Units with its plant standard, thus eliminating possible differences.

Unit

The Engineering Unit shown on the transmitter and the configurator displays may be altered. The units are linked to a selected process variable.

The following units are available:

- For **mV** input: always mV.
- For **Ohm** input: always **Ohm**.
- For **Thermocouple** and **RTD**: **Celsius, Fahrenheit, Rankine and Kelvin degrees.**

Damping

The **DAMPING** option on the **RANGE** function enables electronic damping adjustment. The damping may be adjusted between 0 and 32 seconds.

Trim

The TRIM function is used to adjust resistance, voltage and current reading to user standard. To continue the TRIM adjustment, the control loop must be on MANUAL to avoid disturbances in the process.

There are two options: Current signal and input reading.

Current TRIM (4-20 mA output)

When the microprocessor generates a 0 percent signal, the Digital-to-Analogic converter and related electronic circuits must emit a 4 mA output. If the signal is 100 percent, the output must be 20 mA. Differences may occur between the SMAR standard current and the plant standard. In this case, the current TRIM adjustment should be used.

The Configurator will adjust the output signal and then it will ask again if the current is correct or not.

Input Reading TRIM

There may be differences between the SMAR resistance standard and mV and the plant standards. In this event, the user TRIM adjustment may be used. The TRIM available are: Zero trim, the Gain trim and Factory trim.

- Zero Trim – Calibrates the resistance or millivoltage lower value. The zero trim does not interfere with the gain trim.

- Gain Trim – Calibrates the resistance or millivoltage upper value.

- Factory Trim – Recovers the Zero, Gain, and temperature sensor made in factory.

For zero or gain adjustment, a resistance or mV standard should be connected with a better than 0.02% accuracy.

If the transmitter is configured as either differential sensor, backup, average, maximum or minimum, that is working with two sensors simultaneously, only the zero trim is available.

To perform zero trim, it should to short circuit the two sensors in the field and to enter with the value 0 (zero).

After perform the trim, remove the short circuit for the transmitter to read the sensors resistance without the influence of the lines. The line maximum resistance should be less than 32 Ω for that zero trim would be possible.

Temperature Sensor Trim

Although it is not necessary to perform the temperature trim of the terminal, it is possible a little adjustment in the temperature measure through this menu.

Alarm

This function configures the three **TT301** alarms, with independent configuration for alarms 1 and 2 action and limit. All the alarms may be monitored and identified through this function. Alarm zero indicates burnout and may be activated in this function.

Rec - Recognizes the alarm, while the ACK indication on the transmitter display disappears as the pending alarms are identified.

Action - Configures the alarm operation mode: low, high or off.

Limit - Configures the level that the alarm is occurring.

Alarm Configuration

Low - Is activated when the PV goes below the signal configured (decreasing).

High - Is activated when the PV goes above the signal configured (increasing).

Off - The alarm is disabled.

Online Multidrop Operation

The multidrop connection is made up of several transmitters connected in parallel in a single communication line. The communication between the master system and the transmitters is digitally done, with the transmitter analog output deactivated (TRM mode) or activated (PID mode).

The communication between the transmitters and the master system (PROG, DCS, data acquiring system or PC) is performed through a Bell 202 modem using a HART protocol. Each transmitter is identified by a single (1 to 15) address.

The **TT301** is produced with the address equal to zero, in a point-to-point operational mode. The transmitter communicates with the configurator by overlaying the communication on the 4-20 mA signals. To operate in multidrop mode, the transmitter address must switch to a 1 to 15. This change deactivates the 4-20 mA analog output by assuming the fixed value equal to 4 mA (TRM mode), or maintains the 4-20 mA variable when the equipment is configured for PID mode.

When intrinsic safety is required, special attention must be laid on Ca, La parameters allowed for that area.

To operate in multidrop mode, search for the transmitters connected on the same line. This operation is called "POLL" ("SEARCH") and is automatically performed after "From 0 to 15" is selected and the "POLL" button activated on the Palm configurator screen below:

WARNING
The output current is fixed on 4 mA as soon as the transmitter address is changed, except when the transmitter is configured for PID operation mode.

Configuration TT301 for Multidrop

All equipments leave factory with a 0 (zero) address, unable to work in multidrop. To operate in multidrop they must be singly connected to any number between 1 and 15.

To configure the transmitter in multidrop, connect it single on the line according to figure 1.6 on section 1.

After powering it, press the **HPC30pt** icon. The configurator will display the following screen:

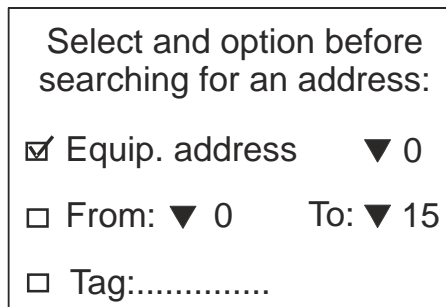

Figure 3.4 – Multidrop Configuration Screen

Select **Equipment Address 0** on the first line and press the **Poll** button. When the configurator identifies the transmitter, select a line containing the information on the equipment. On next screen, choose the **Multidrop** option. Now, select the required transmitter address and press **Send**. See that no other required transmitter on same line has the same address, regardless of make, model and type. Repeat this procedure for all equipments connected in multidrop.

Multidrop Mode Configuration

To use the configurator for communication with a specific transmitter in multidrop mode, select the second option **From: 0 to 15** on the configurator screen and press the **Poll** button. When the configurator identifies a transmitter on the line, it will display a list with its **Address, Tag and Manufacturer**.

After the transmitter is selected, the main menu with all configuration options will be displayed on the configurator for handling.

Section 4

PROGRAMMING USING LOCAL ADJUSTMENT





The Magnetic Tool

Smar's magnetic tool is the second man-machine interface; it comprises the advantage of the powerful Smar Configurator and the convenience of the "good-old" tool.

If the transmitter is fitted with a display, and is configured for complete - local - adjustment (using internal jumper) the magnetic tool is almost as powerful as the **Configurator**, eliminating the need for a **Configurator** in most basic applications.

If the transmitter is not fitted with a display, or is configured for simple local adjustment (using internal jumper) the adjustment capability is reduced to reranging.

To select the function mode of the magnetic switches configure the jumpers located at the top of the main circuit board as indicated below:

SI/COM OFF/ON	NOTE	WRITE PROTECT	SIMPLE LOCAL ADJUSTMENT	COMPLETE LOCAL ADJUSTMENT
		Disables	Disables	Disables
	1	Enables	Disables	Disables
	2	Disables	Enables	Disables
		Disables	Disables	Enables

NOTE

If the hardware protection is selected, the EEPROM will be protected.
 The local adjustment default condition is simple enabled and write protect disabled.

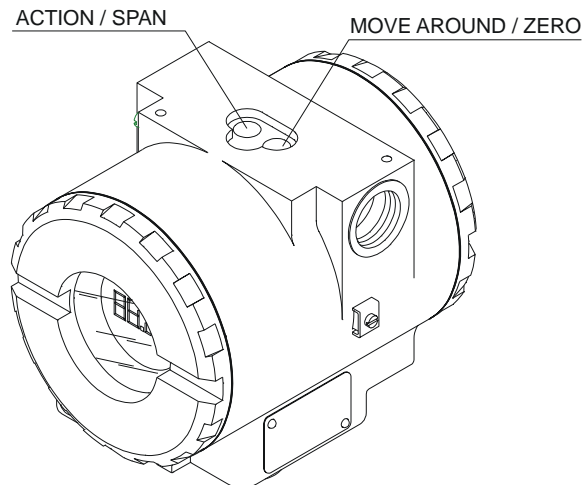

Figure 4.1 – Local Adjustment Switches

The transmitter has, under the identification plate, holes for two magnetic switches activated by the magnetic tool.

The holes are marked with **Z** (Zero) and **S** (Span). If "**Simple Local Adjustment**" is selected by the jumpers position, the switches have the following functions:

Transmitter mode:

Z - It is used to select the Lower Range Value.

S - It is used to select the Upper Range Value.

They work exactly as the adjustment with reference of the **Configurator** controller mode for transmitters with digital display.

Controller mode:

Z - Moves the options (**OPERATION** and **BATCH**).

S - Activates the selected function.

If "**Complete Local Adjustment**" is selected by the jumpers position, the switches have the following functions:

Z - Moves the options.

S - Activates the selected function.

Reranging Using the Local Zero and Span Adjustments in Simple Mode

It is possible to rerange the transmitter with the local adjustment switches located on the top of the electronic housing. The switches work like the adjustment "with reference" for the **Configurator**.

In order to make these adjustments, the instrument must be configured as "transmitter" (XMTR).

To adjust the zero of the transmitter, proceed as follows:

- ✓ Apply the Lower Value, signal.
- ✓ Wait for the process to stabilize.
- ✓ Insert the magnetic tool in the ZERO adjustment hole (see Figure 4.2)
- ✓ Wait 2s. The transmitter should be reading 4 mA.
- ✓ Remove the tool.

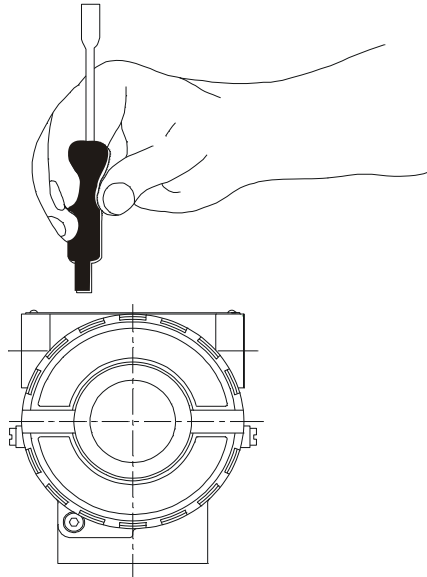

Figure 4.2 – Local Zero and Span Adjustment

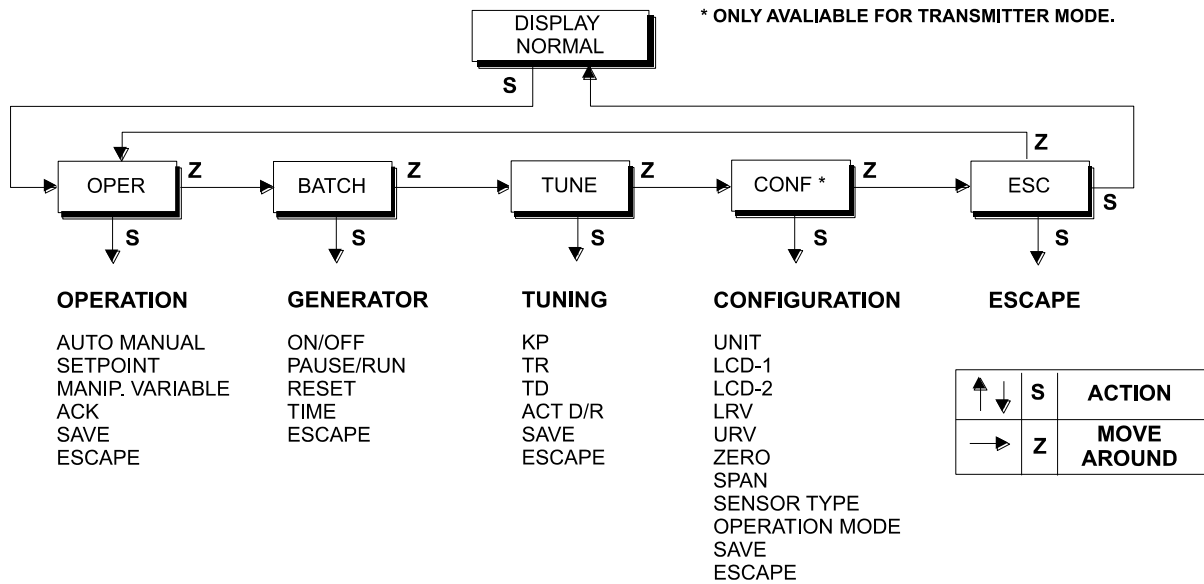

Figure 4.3 - Local Adjustment Programming Tree – Main Menu

As the reranging with reference, the span is maintained. In case you want to change the span, proceed as follows:

- ✓ Apply the Upper Value, signal.
- ✓ Wait for the process to stabilize.
- ✓ Insert the magnetic tool in the SPAN adjustment hole.
- ✓ Remove the tool.

Note that when zero adjustment is done, the URV can not be pushed above the URL. In this case, span is not maintained.

Complete Local Adjustment

LOCAL PROGRAMMING TREE

The programming tree is a tree-shaped structure with a menu of all available software resources, as shown in Figure 4.3.

The Local Programming mode is entered by activating switch (Z). In transmitter mode, only the configuration branch of the tree is applicable, thus the first menu function will be UNIT.

WARNING

When programming using local adjustment, the transmitter will not prompt "Control loop should be in manual!" as it does when programming using the **Configurator**. Therefore it is a good idea, prior to configuration, to switch the loop to manual. And do not forget to return to auto after configuration is completed

OPER (OPERATION): Is the option where the operation related parameters of the controller are configured: Auto/ Manual, Setpoint, Manual output.

BATCH: Is the option where the Setpoint generator related functions are operated: on/off, Pause, Reset and time adjustment.

TUNE (TUNING): Is the option where the PID-Algorithm related parameters are configured: Action, K_p, T_r, and T_d.

CONF (CONFIGURATION): Is the option where the output and display related parameters are configured: unit, primary and secondary display, Lower and Upper Value, damping, sensor type and operation mode.

ESC (ESCAPE): Is the option used to go back to normal monitoring mode.

Operation [OPER]

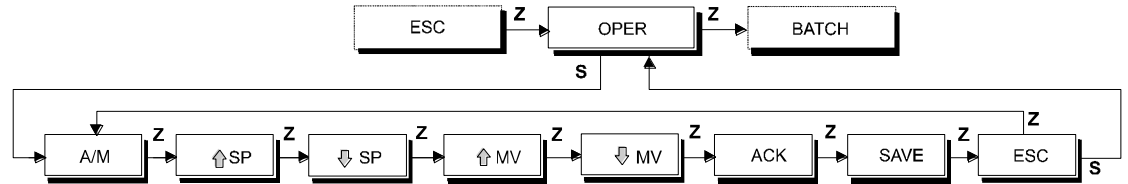
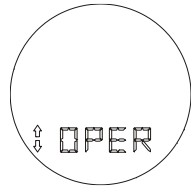

Figure 4.4 – Local Adjustment Operation Tree



Z: Moves to the next branch (BATCH).

S: Enters the OPERATION branch, starting with function AUTO/MANUAL.

Auto/Manual (A/M)

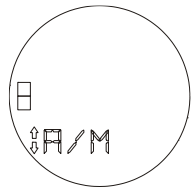

Z: Moves to the SETPOINT INCREASE function.

S: Toggles controller status, Automatic to Manual or Manual to Automatic. “A” and “M” indicates status.

Setpoint Adjustment (SP)

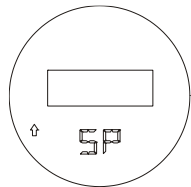

Z: Moves to the SETPOINT DECREASE function.

S: Increases the setpoint until the magnetic tool is removed or 100% is reached.

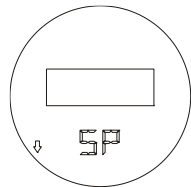

Z: Moves to the MANIPULATED VARIABLE ADJUSTMENT function.

S: Decreases the setpoint until the magnetic tool is removed or 0% is reached.

Manipulated Variable Adjustment (MV)

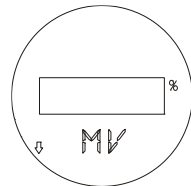

Z: Moves to the MANIPULATED VARIABLE DECREASE function.

S: Increases the control output until the magnetic tool is removed or the upper output limit is reached.

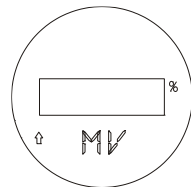

Z: Moves to the ACK function.

S: Decreases the control output until the magnetic tool is removed or the lower output limit is reached.

Acknowledge (ACK)



- Z:** Moves the SAVE function.
- S:** Acknowledges all alarms.

Save (SAVE)

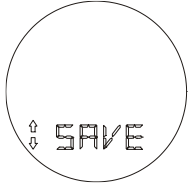

- Z:** Moves to ESCAPE of the operation menu.
- S:** Saves the setpoint and manual output values in the transmitter EEPROM, for use after power-on.

Escape (ESC)

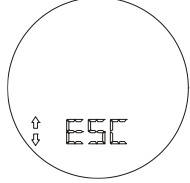

- Z:** Moves to the AUTO/ MANUAL function.
- S:** Escapes to the MAIN menu.

Batch [BATCH]

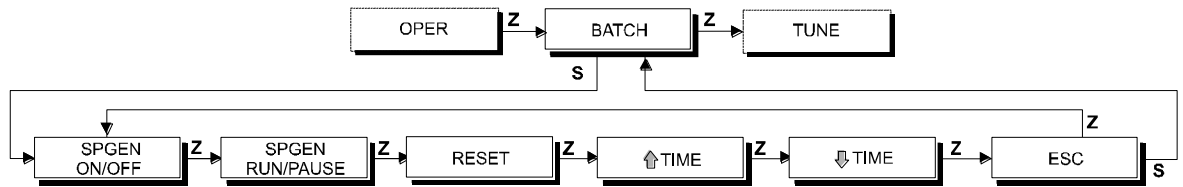
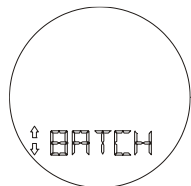
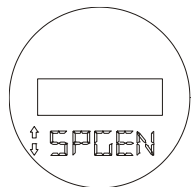

Figure 4.5 – Local Adjustment Batch Tree



- Z:** Moves to the TUNING branch.
- S:** Enters the BATCH branch, starting with function SPGEN on/off.

Setpoint Generator On/Off (SPGEN)



- Z:** Moves to the SPGEN Pause/ Run function.
- S:** Toggles setpoint generator. On to Off or Off to On.

Setpoint Generator Pause/Run (SPGEN)

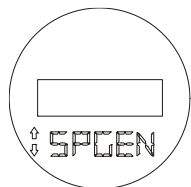

- Z:** Moves to the RESET function.
- S:** Toggles setpoint generator mode, pause to run or run to pause.

Reset (RESET)

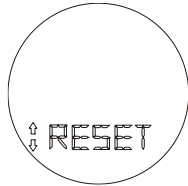

Z: Moves to the TIME INCREASE function.

S: Resets the time register of the setpoint generator to 0.

Time (TIME)

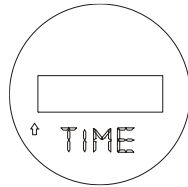

Z: Moves to the time decrease function.

S: Increases the time register for the setpoint generator until the magnetic tool is removed or 19999 min. is reached.

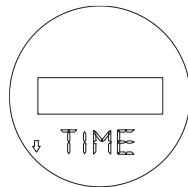

Z: Selects ESCAPE of the BATCH menu.

S: Decreases the time register for the setpoint generator until the magnetic tool is removed or the time-base register is zero.

Escape (ESC)

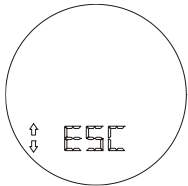

Z: Moves to the SPGEN on/off function.

S: Escapes to the MAIN menu.

Tuning [TUNE]

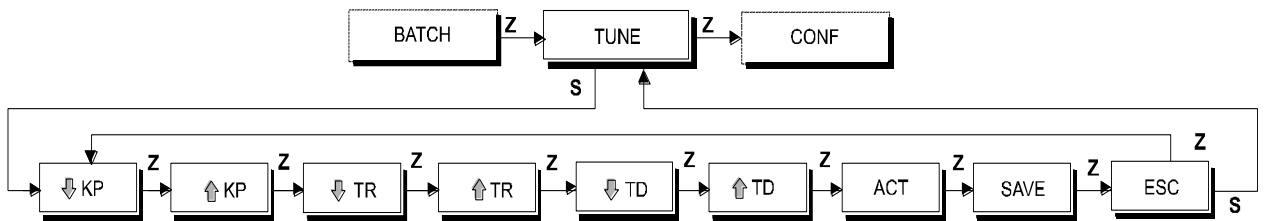
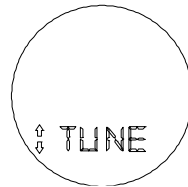

Figure 4.6 – Local Adjustment Tuning Tree



Z: Moves to the CONFIGURATION branch.

S: Enters the TUNING branch, starting with function KP-ADJUSTMENT.

Kp - Adjust (KP)

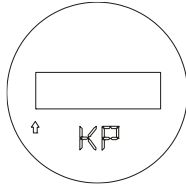

Z: Moves to the proportional gain decrease function.

S: Increases the proportional gain until the magnetic tool is removed or 100 is reached.

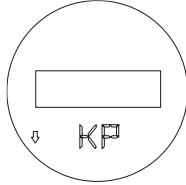

Z: Moves to the TR_ADJUSTMENT function.

S: Decreases the proportional gain until the magnetic tool is removed or 0.0 is reached.

Tr - Adjust (TR)

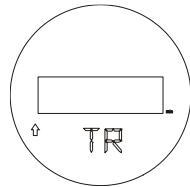

Z: Moves to the integral time decrease function.

S: Increases the integral time until the magnetic tool is removed or 999 minutes are reached.

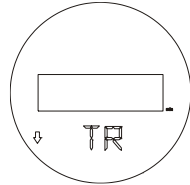

Z: Moves to the TD_ADJUST function.

S: Decreases the integral time until the magnetic tool is removed or 0 minute is reached.

Td - Adjust (TD)

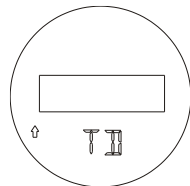

Z: Moves to the derivative time decrease function.

S: Increases the derivative time until the magnetic tool is removed or 999 seconds are reached.

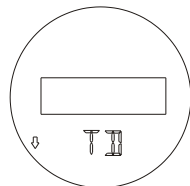

Z: Moves to the ACTION function.

S: Decreases the derivative time until the magnetic tool is removed or 0 second is reached.

Action (ACT)

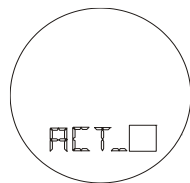

Z: Moves to the SAVE function.

S: Toggles the action direct to reverse or reverse to direct.

The far-right character of the unit/function-field indicates the present mode:

D = direct action

R = reverse action

Save (SAVE)

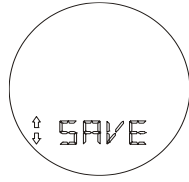

Z: Moves to the ESCAPE to TUNING menu.

S: Saves the KP, TR and TD constants in the transmitter EEPROM.

Escape (ESC)

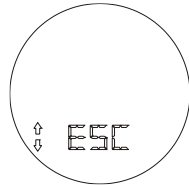

Z: Moves to the KP-ADJUSTMENT function.

S: Escapes to the MAIN menu.

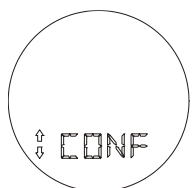

Z: Selects ESCAPE of the monitoring mode.

S: Enters the CONFIGURATION branch, starting with function UNIT.

Unit (UNIT)

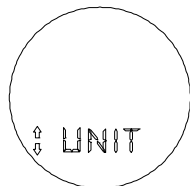

Z: Moves to the DISPLAY-1 function.

S: Starts selection of engineering unit for process variable and setpoint indication. After activating (S), you can move around the options available in the table below by activating (Z).

DISPLAY	DESCRIPTION
C	Degree Celsius
F	Degree Fahrenheit
R	Degree Rankine
K	Kelvin
mV	millivolt
Ohm	Ohm
SPEC	Special Unit
NO	No Unit
ESC	-escape-

The desired unit is activated by using (S). Escape leaves unit unchanged.

NOTE
See special sensor in Section 3 for more information on “special unit”.

Display 1 (LCD_1)

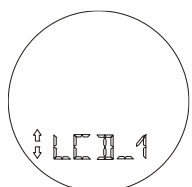

Z: Moves to the DISPLAY-2 function.

S: Starts selection of variable to be indicated as primary display. After activating (S), you can move around the options available in the following table by activating (Z).

DISPLAY	DESCRIPTION
SP%	Setpoint (%)
PV%	Process Variable (%)
MV%	Output (%)
ER%	Error (%)
<input type="checkbox"/>	Nothing
TI	SP generator time
CU	Output (mA)
PV	Process Variable (eng. unit)
SP	Setpoint (eng. unit)
ESC	-escape-

The desired variable is activated using (A). Escape leaves primary variable unchanged.

NOTE

In TRANSMITTER mode, only PV%, CU, PV and "none" are selectable.

Display 2 (LCD_2)

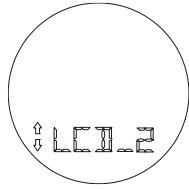

Z: Moves to the ZERO ADJUST function.

S: Starts selection of variable to be indicated as secondary display.

The procedure for selection is the same as for DISPLAY_1, above.

Lower Range Value Adjustment without Reference (LRV)

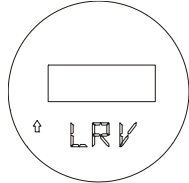

Z: Moves to the LRV decrease function.

S: Increases the Lower Value until the magnetic tool is removed or the maximum for the Lower Value is reached.

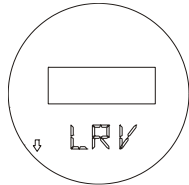

Z: Moves to the URV ADJUST-MENT function.

S: Decreases the Lower Value until the magnetic tool is removed or the minimum for the Lower Value is reached.

Upper Range Value Adjust without Reference (URV)

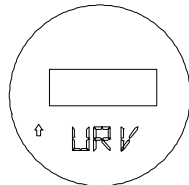

Z: Moves to the URV decrease function.

S: Increases the Upper Value until the magnetic tool is removed or the maximum for the Upper Value is reached.

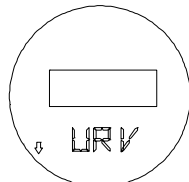

Z: Moves to the ZERO ADJUSTMENT function.

S: Decreases the Upper Value until the magnetic tool is removed or the minimum for the Upper Value is reached.

Reranging using the LRV and URV items in the menu is the same as the keyboard rerange on the CONFIGURATOR. No input has to be applied; the range is set independent of applied input. Adjust the value indicated on the display to the desired range value. Changing one does not affect the other.

Zero Adjust with Reference (ZERO)

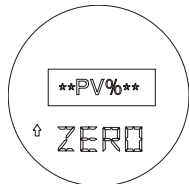

Z: Moves to the ZERO decrease function.

S: Decreases the Lower Value (Increases output) until the magnetic tool is removed or the minimum for the Lower Value is reached.



Z: Moves to the SPAN ADJUST function.

S: Increases the Lower Value (Decreases Output) until the magnetic tool is removed or the maximum for the Lower Value is reached.

Span Adjust with Reference (SPAN)

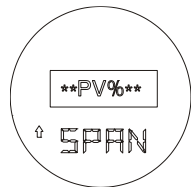

Z: Moves to the SPAN decrease function.

S: Decreases the Upper Value (Increases Output) until the magnetic tool is removed or the minimum for the Upper Value is reached.

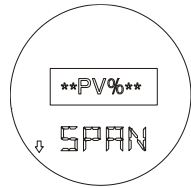

Z: Moves to the SENSOR function.

S: Increases the Upper Value (Decreases output) until the magnetic tool is removed or the maximum for the Upper Value is reached.

Reranging using the ZERO and SPAN items in the menu is equivalent to the applied rerange on the Configurator. The range values are adjusted relative to the applied input. The value in the display is the applied temperature in percentage of the range. Changing the lower value shifts the upper value too, maintaining the span. Changing the upper value does not affect the lower value. For example, if you want 4 mA (0%) for the applied input, adjust until the display reads 0%. Likewise, if you want 20% (7.2 mA), adjust until the display shows 20%.

Sensor (SENS)

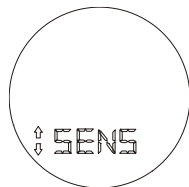

Z: Moves to the OPERATION MODE function.

S: This function is protected by a "password", when prompted PSWD activate (S) 2 times to proceed with sensor selection.

After activating (S), you can move around the options available in the following table by activating (Z).

SENSOR SELECTION TABLE	
DISPLAY	DESCRIPTION
mV-1	-6 to 22 mV
mV-2	-10 to 100 mV
mV-3	-20 to 500 mV
Ohm-1	0 to 100 Ohm
Ohm-2	0 to 400 Ohm
Ohm-3	0 to 2000 Ohm
RTD	RTD
TC	Thermocouple
SPEC	Special Sensor
ESC	- escape -

For all sensors, further selections must be done to determine the specific type and connection. Move around the available options - listed in the tables below - using (Z).

RTD SELECTION TABLE			
DISPLAY	DESCRIPTION	DISPLAY	DESCRIPTION
Cu-10	Cu10	Mi100	MILT Pt100
Ni 120	Ni 120	Mi120	MILT Ni120
I50	IEC Pt50	IE100	IEC751-95 Pt100
I100	IEC Pt100	Go50	GOST Pt50
Ji 50	JIS Pt50	Go100	GOST Pt100
Ji 100	JIS Pt100	Cu50	GOST Cu50
I500	IEC Pt500	Cu100	GOST Cu100
I1000	IEC Pt1000	Esc	Escape

OHMS & RTD CONNECTION	
DISPLAY	DESCRIPTION
2 WIRE	2 - wire
3 WIRE	3 - wire
4 WIRE	4 - wire
DIFF	Differential
ESC	- escape -

THERMOCOUPLE - TYPE			
DISPLAY	DESCRIPTION	DISPLAY	DESCRIPTION
B_NBS	NBS type B	WR26	ASTM W5Re/W25Re
E_NBS	NBS type E	L GOS	GOST Type L
J_NBS	NBS type J	ESC	Escape
K_NBS	NBS type K		
N_NBS	NBS type N		
R_NBS	NBS type R		
S_NBS	NBS type S		
T_NBS	NBS type T		
L_DIN	DIN type L		
U_DIN	DIN type U		

Operation Mode (MODE)

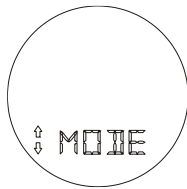

Z: Moves to the SAVE function.

S: This function is protected by a "password", when prompted PSWD activate (S) 2 times to proceed.

After entering the "password", you can move around the options listed in the table below using (Z). In order to select the desired option, activate (S).

OPERATION MODE	
DISPLAY	DESCRIPTION
XMTR	Transmitter
CNTRL	Controller (Optional)

Save (SAVE)

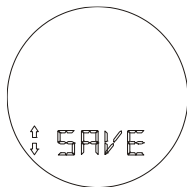

Z: Selects ESCAPE to CONFIGURATION mode.

S: Saves lower value and upper value.

Escape (ESC)

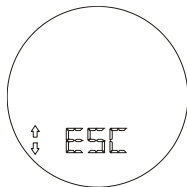

Z: Moves to the UNIT function.

S: Escapes to the MAIN menu.

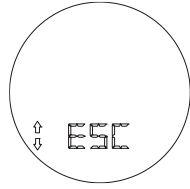

ESCAPE [ESC]

Z: Selects OPERATION branch.

S: Escapes to MONITOR mode.

Section 5

MAINTENANCE PROCEDURES

General

SMAR TT301 intelligent temperature transmitters are extensively tested and inspected before delivery to the end user. Nevertheless, during their design and development, consideration was given to the possibility of repairs by the end user, if necessary.

In general, it is recommended that the end user do not try to repair printed circuit boards. Instead he should have spare circuit boards, which may be ordered from **SMAR** whenever necessary.

Diagnosis with Smar Configurator

Should any problem be noticed related to the transmitter's output, investigation may be carried out by the Configurator, as long as power is supplied and communication and the processing unit are operating normally.

The programmer should be connected to the transmitter in accordance with the wiring diagram shown on Section 1, Figures 1.4, 1.5 and 1.8.

Error Messages

When communicating using the Configurator the user will be informed about any problem found by the transmitters self diagnostics.

As an example, the Configurator of the display may show:

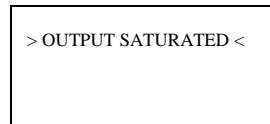

The messages are always alternated with the information on the top line. The table below lists the error messages. Refer to trouble shooting for more details on corrective action.

Diagnostics with the Configurator

DIAGNOSTIC MESSAGES	POTENTIAL SOURCE OF PROBLEM
PARITY ERROR	<ul style="list-style-type: none">• Excessive noise or ripple.
OVERRUN ERROR	<ul style="list-style-type: none">• Excessive noise or ripple.
CHECK SUM ERROR	<ul style="list-style-type: none">• Excessive noise or ripple.
FRAMING ERROR	<ul style="list-style-type: none">• Excessive noise or ripple.
NO RESPONSE	<ul style="list-style-type: none">• The line resistance is not in accordance with load curve.• Transmitter not powered.• Interface not connected.• Transmitter configured in Multidrop mode being accessed by ON LINE SINGLE UNIT.• Transmitter reversely powered (polarity is reversed).• Interface damaged.• Power supply or battery voltage of the Configurator lower than 9 V.
LINE BUSY	<ul style="list-style-type: none">• Other device using the line.
CMD NOT IMPLEMENTED	<ul style="list-style-type: none">• Software version not compatible between Configurator and transmitter.• Configurator is trying to carry out a TT301 specific command in a transmitter from another manufacturer.
TRANSMITTER BUSY	<ul style="list-style-type: none">• Transmitter carrying out on important task. e.g., Local Adjustment.
COLD START	<ul style="list-style-type: none">• Start-up or Reset due to power supply failure.
OUTPUT FIXED	<ul style="list-style-type: none">• Output in Constant Mode.• Transmitter in Multi-drop mode.

DIAGNOSTIC MESSAGES	POTENTIAL SOURCE OF PROBLEM
OUTPUT SATURATED	<ul style="list-style-type: none"> • Primary variable out of calibrated Span (Output current in 3.8 or 20.5 mA, XMTR mode only).
SV OUT OF LIMITS	<ul style="list-style-type: none"> • Temperature out of operating limits. • Temperature sensor damaged.
PV OUT OF LIMITS	<ul style="list-style-type: none"> • Input signal out of operating limits. • Sensor damaged. • Transmitter with false configuration. • PV out of range limits (see table).

Table 1 - Diagnostics with the Configurator

Troubleshooting with Transmitter

- **Symptom: NO LINE CURRENT**

Probable Source of Trouble:

- **Transmitter Connections**

- Check wiring polarity and continuity.
- Check for shorts or ground loops.

- **Power Supply**

- Check power supply output. The voltage at the **TT301** terminals must be between 12 and 45 Vdc, and the ripple less than 0.4V.

- **Electronic Circuit Failure**

- Check the main board for defect by replacing it with a spare one.

Symptom: NO COMMUNICATION

Probable Source of Trouble:

- **Terminal Connections**

- Check terminal interface connections.
- Check if the interface is connected to the points [COMM] and [-] or in the line between the transmitter and the load resistor.
- Check if the interface is model IF2 (for HART Protocol).

- **Transmitter Connections**

- Check if connections are as per wiring diagram.
- Check line resistance; it must be equal to or greater than 250 Ohm, between the transmitter and the power supply.

- **Power Supply**

- Check output of power supply. The voltage at the **TT301** terminals must be between 12 and 45V, and ripple less than 0.4V.

- **Electronic Circuit Failure**

- Locate the failure by alternately replacing the transmitter circuit and the interface with spare parts.

- **Transmitter Address**

- In On Line Multidrop item check if the address is "0".

Symptom: CURRENT OF 21.0 mA OR 3.6 mA**Probable Source of Trouble:**

- **Transmitter Connection**
 - Check if the sensor is correctly connected to the **TT301** terminal block.
 - Check if the sensor signal is reaching the **TT301** terminal block by measuring it with a multimeter at the transmitter-end. For mV and thermocouples test can be done with connected and disconnected to the transmitter.
- **Sensor**
 - Check the sensor operation; it shall be within its characteristics.
 - Check sensor type; it shall be the type and standard that the **TT301** has been configured to.
 - Check if process is within the range of the sensor and the **TT301**.

NOTE

A 21.0 or 3.6mA current in XMTR mode indicates burnout.

Symptom: INCORRECT OUTPUT**Probable Source of Trouble:**

- **Transmitter Connections**
 - Check power supply voltage. The voltage at the **TT301** terminals must be between 12 and 45V, and ripple less than 0.4V.
 - Check for intermittent short circuits, open circuits and grounding problems.
- **Noise, Oscillation**
 - Adjust damping
 - Check grounding of the transmitters housing, extra important for mV and thermocouple input.
 - Check the terminal block for moisture.
 - Check that the shielding of the wires between sensor/transmitter and transmitter/panel is grounded only in one end.
- **Sensor**
 - Check the sensor operation; it shall be within its characteristics.
 - Check sensor type; it shall be the type and standard that the **TT301** has been configured to.
- **Electronic Circuit Failure**
 - Check the integrity of circuit replacing it with a spare one.
- **Calibration**
 - Check calibration of transmitter.

Disassembly Procedure

Refer to Figure 5.1. Make sure to disconnect power supply before disassembling the transmitter.

Sensor

If the sensor is mounted on the transmitter, first disconnect the wires in order to prevent the wires from breaking. To access the terminal block, first loose the cover locking screw on the side marked "Field Terminals", then unscrew the cover.

Electronic Circuits

The main board (**6**) and input board (**9**) are matched pairs and must be changed together and not mixed with others.

To remove the circuit boards (**6** and **9**) and display (**4**), first loose the cover locking (**10**) on the side not marked "Field Terminals" then unscrew the cover (**1**).

WARNING:

The board has CMOS components which may be damaged by electrostatic discharges. Observe correct procedures for handling CMOS components. It is also recommended to store the circuit boards in electrostatic-proof cases.

Loosen the two screws (5) that anchor the main circuit board. Gently pull out the main board (6). To remove the input board (9), first unscrew the two screws (8) that anchors it to the housing (11), gently pull out the board.

Reassembly Procedure

- Put input board (9) into housing (11).
- Anchor input board with its screws (8).
- Put main board (6) into the housing, ensuring all inter connecting pins are connected.
- Anchor main board with their screws (5).
- Put display (4) into the housing, observing the four mounting positions (see Figure 5.2) "▲" symbol should point in the direction desired as UP.
- Anchor display with their screws (3).
- Fit the cover (1) and lock it using the locking screw (10).

Interchangeability

Calibration data is stored in the EEPROM of the main board, hence READING TRIM must be done if main-board or input board has been changed.

Returning Materials

Should it become necessary to return the transmitter and/or Configurator to **SMAR**, simply contact your local agent or **SMAR** office, informing the defective instrument's serial number, and return it to our factory.

In order to expedite analysis and solution of the problem, the defective item should be returned with a description of the failure observed, with as much details as possible. Other information concerning to the instrument operation, such as service and process conditions, is also helpful.

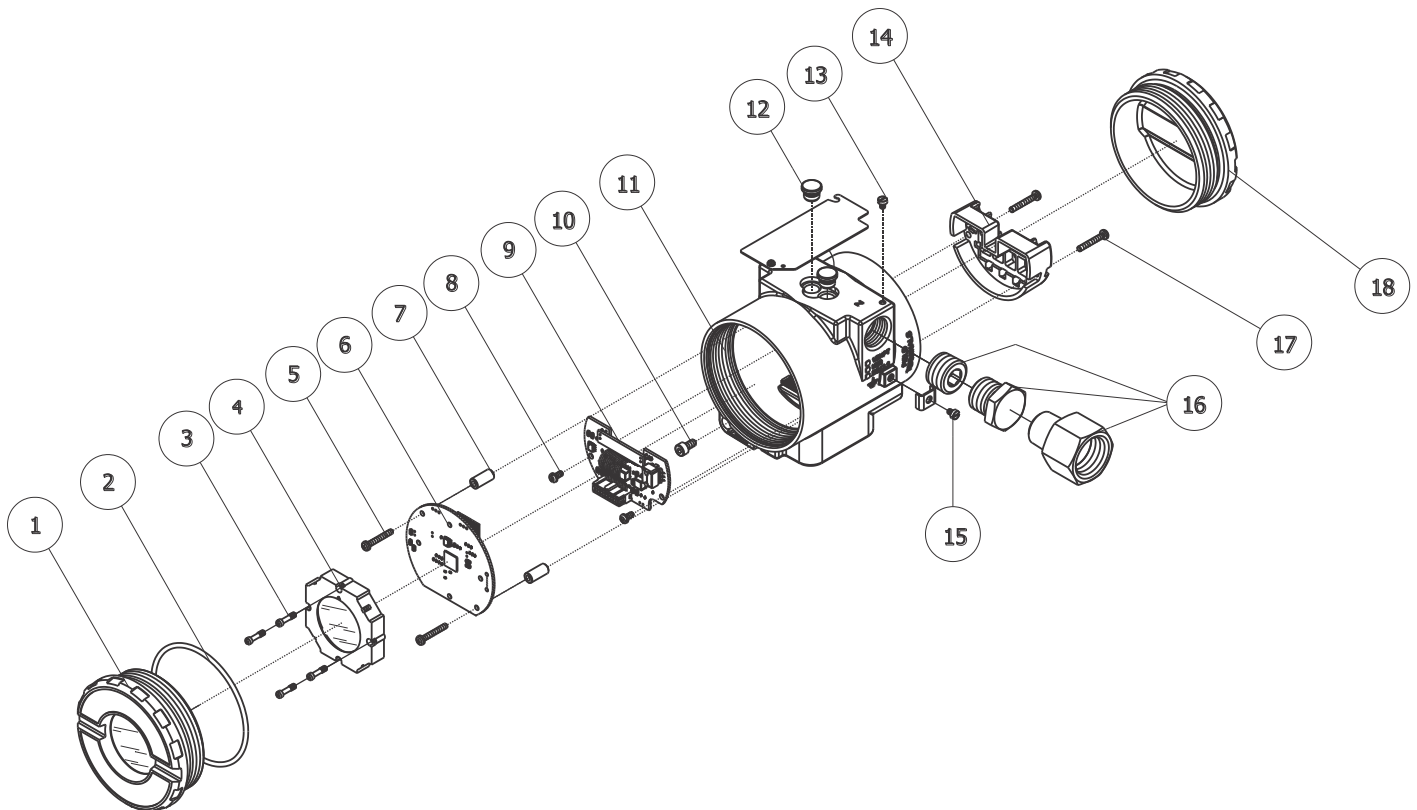

Figure 5.1 – Exploded View

NOTE

For housing in aluminium there is an insert in the position 15. This insert is used to improve the grounding.

ACCESSORY	
ORDERING CODE	DESCRIPTION
SD-1	Magnetic Tool for local adjustment.
Palm*	16 Mbytes Palm Handheld, Including HPC301's initialization and installation software.
HPC301*	HART® HPI311-M5P for the Palm, including the configuration package for the Smar and generic transmitters.
HPI311-M5P*	HART® interface.

* For equipment updates and HPC301 software, just check: <http://www.smarresearch.com>.

SPARE PARTS LIST FOR TRANSMITTER			
DESCRIPTION OF PARTS	POSITION	CODE	CATEGORY
HOUSING, Aluminum (NOTE 2)			
. See Housing Ordering Code	11		
HOUSING, 316 SS (NOTE 2)			
. See Housing Ordering Code	11		
COVER			
. See Cover Ordering Code	1 and 18		
COVER WITH WINDOW FOR INDICATION			
. See Cover Ordering Code	1		
COVER LOCKING SCREW	10	204-0120	
EXTERNAL GROUND SCREW	15	204-0124	
IDENTIFICATION PLATE FIXING SCREW	13	204-0116	
DIGITAL AND MOUNTING KIT INCLUDED	3 and 4	400-1310	
TERMINAL HOLDER INSULATOR	14	214-0220	
GLL1473 AND GLL1474 SET (DISPLAY AND MOUNTING KIT INCLUDED); TT301 (RVMP)	5, 6, 7, 8 and 9	400-1425	A
BOARD/GROUP GLL1473 AND GLL1474 (WITHOUT DISPLAY. ASSEMBLY KIT INCLUDED); TT301 (RVMP)	5, 6, 7, 8 and 9	400-1426	A
0-RINGS Cover, BUNA-N (NOTE 3)	2	204-0122	B
TERMINAL HOLDING SCREW	17	204-0119	
CONDUIT PLUG			
1/2 NPT Internal Socket Set Plug in Bichromatized Carbon Steel	16	400-0808	
1/2 NPT Internal Socket Set Plug in 304 SST	16	400-0809	
M20 X 1.5 External Socket Set Plug in 316 SST	16	400-0810	
PG 13.5 External Socket Set Plug in 316 SST	16	400-0811	
MOUNTING BRACKET FOR 2" PIPE MOUNTING (NOTE 4)			
. Carbon Steel (Accessories in Carbon Steel)	-	214-0801	
. Stainless Steel 316 (Accessories in Stainless Steel 316)	-	214-0802	
. Carbon Steel (Accessories in Stainless Steel 316)	-	214-0803	
LOCAL ADJUSTMENT PROTECTION CAP	12	204-0114	

NOTE

- 1 - For category A, it is recommended to keep, in stock, 25 parts installed for each set, and for category B, 50.
- 2 - It includes terminal holder insulator, bolts (cover lock, grounding and terminal holder insulator) and identification plate without certification.
- 3 - 0-Rings are packaged in packs of 12 units.
- 4 - Including U-clamp, nuts, bolts and washers.

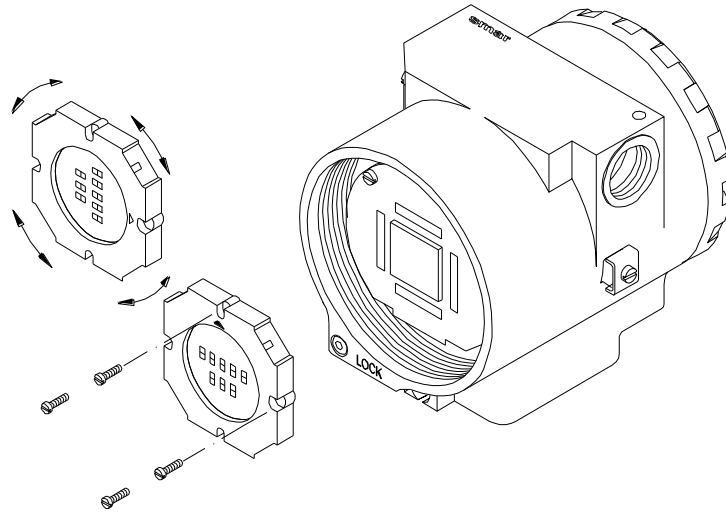

Figure 5.2 – Four Possible Positions of the Display

Housing Ordering Code

400-1315-1 TEMPERATURE INTELLIGENT TRANSMITTER HOUSING TT301						
COD. Communication Protocol						
0	4 - 20 mA					
H	HART & 4 A 20 mA					
T	HART & 0 - 20 mA					
COD. Electrical Connection						
0	½ NPT					
A	M20x1,5					
B	PG13,5 DIN					
COD. Material						
H0	Aluminium					
H1	316 SST					
H2	Aluminium for Saline Atmosphere					
H4	Cooper Free Aluminium					
COD. Painting						
P0	Gray Munsell N6.5					
P1	Safety Blue N4845 (Standard 1374 - Petrobras)					
P2	Safety Blue N4845 (Standard 1735 - Petrobras)					
P3	Polyester Black					
P7	Painting According to Procedure PDM-FAB020-01					
P8	Without Painting					
P9	Blue Safety Base Epóxi - Electrostatic Painting					
COD. Manufacturing Standard						
S0	Smr					
COD. Applicable Certification						
I0	All except CSA					
I3	CSA					
400-1315-1	H	0	H0	P0	S0	I0

Cover Ordering Code

400-1307 COVER FOR ALL LINE 300				
COD. Type				
0	Without Display			
1	With Display			
COD. Material				
H0	Aluminium (IP/TYPE)			
H1	316 SST (IP/TYPE)			
COD. Painting				
P0	Gray Munsell N6.5			
P1	Safety Blue N4845 (Standard 1374 - Petrobras)			
P2	Safety Blue N4845 (Standard 1735 - Petrobras)			
P3	Polyester Black			
P7	Painting According to Procedure PDM-FAB020-01			
P8	Without Painting			
P9	Blue Safety Base Epóxi - Electrostatic Painting			
400-1307	1	H0	P0	

Section 6

TECHNICAL CHARACTERISTIC

Functional Specifications													
Inputs	See table 6.1, 6.2 and 6.3												
Output Signal	Two-wire, 4-20 mA with superimposed digital communication (HART Protocol Version 5.1/Transmitter/Poll-Response mode/Common 4-20 mA).												
Power Supply	Bus powered: 12 - 45 Vdc.												
Load Limitation													
Display	Optional 4 1/2 digit LCD indicator.												
Hazardous Area Certifications	Intrinsic Safety (FM, CSA, EXAM, CEPEL), Explosion Proof (FM, CSA, NEMKO, CEPEL), Dust Ignition Proof (FM), Non-incendive (FM)												
European Directive Information	<p>Authorized representative in European Community Smar GmbH-Rheingastrasse 9-55545 Bad Kreuznach</p> <p>EMC Directive (2004/108/EC) – Electromagnetic Compatibility The EMC test was performed according to IEC standard: IEC61326-1:2006, IEC61326-2-3:2006, IEC61000-6-4:2006, IEC61000-6-2:2005. For use only in industrial environment.</p> <p>ATEX Directive (94/9/EC) – Equipment and protective systems intended for use in potentially explosive atmospheres. This product was certified according European Standards at NEMKO and EXAM (former DMT). The certified body for manufacturing quality assessment is EXAM (number 0158).</p> <p>LVD Directive 2006/95/EC – Electrical Equipment designed for use within certain voltage limits According the LVD directive Annex II the equipment under ATEX “Electrical equipment for use in an explosive atmosphere” directive are excluded from scope from this directive.</p>												
Zero and Span Adjustments	No interactive, via digital communication or local adjustment.												
Temperature Limits	<table border="0"> <tr> <td>Ambient:</td> <td>-40 °C to 85 °C</td> <td>(-40 °F to 185 °F)</td> </tr> <tr> <td>Storage:</td> <td>-40 °C to 120 °C</td> <td>(-40 °F to 248 °F)</td> </tr> <tr> <td>Display:</td> <td>-20 °C to 80 °C</td> <td>(-4 °F to 176 °F)</td> </tr> <tr> <td></td> <td>-40 °C to 85 °C</td> <td>(-40 °F to 185 °F) (without damage)</td> </tr> </table>	Ambient:	-40 °C to 85 °C	(-40 °F to 185 °F)	Storage:	-40 °C to 120 °C	(-40 °F to 248 °F)	Display:	-20 °C to 80 °C	(-4 °F to 176 °F)		-40 °C to 85 °C	(-40 °F to 185 °F) (without damage)
Ambient:	-40 °C to 85 °C	(-40 °F to 185 °F)											
Storage:	-40 °C to 120 °C	(-40 °F to 248 °F)											
Display:	-20 °C to 80 °C	(-4 °F to 176 °F)											
	-40 °C to 85 °C	(-40 °F to 185 °F) (without damage)											
Loss of Input (Burnout)/Failure Alarm	In case of sensor burnout or circuit failure, the self diagnostics drives the output to 3.6 or to 21.0 mA, according to the user's choice.												
Humidity Limits	0 to 100% RH												
Turn-on Time	Performs within specifications in less than 10 seconds after power is applied to the transmitter.												
Update Time	Approximately 0.5 second.												
Damping Adjustment	User configurable from 0 to 32 seconds (via digital communication).												
Configuration	This is done by an external Configurator that communicates with the transmitter remote or locally using Hart Protocol. Locally the magnetic tool can be used as well. The magnetic tool can configure the majority of the items provided the transmitter is fitted with a display.												

Performance Specifications	
Accuracy	See tables 6.1, 6.2, 6.3 and 6.4.
Ambient Temperature Effect	<p>For a 10 °C variation: mV (- 6 to 22 mV), TC (NBS: B, R, S, T): ± 0.03% of the input millivoltage or 0.002 mV whichever is greater; mV (- 10 to 100 mV), TC (NBS: E, J, K, N; DIN: L, U): ± 0.03% of the input millivoltage or 0.01 mV whichever is greater; mV (-50 to 500 mV): ± 0.03% of the input millivoltage or 0.05 mV whichever is greater; Ohms (0 to 100Ω), RTD (GE: Cu10): ± 0.03% of the input resistance or 0.01Ω whichever is greater;</p>

Performance Specifications	
Ambient Temperature Effect	Ohms (0 to 400Ω), RTD (DIN: Ni120; IEC: Pt50, Pt100; JIS: Pt50, Pt100): ± 0.03% of the input resistance or 0.04 Ω whichever is greater; Ohms (0 to 2000Ω), RTD (IEC: Pt500), RTD (IEC: Pt1000): ± 0.03% of the input resistance or 0.2 Ω whichever is greater; TC: cold-junction compensation rejection 60:1 (Reference: 25.0 ± 0.3 °C).
Power Supply Effect	± 0.005% of calibrated span per volt.
Vibration Effect	Meets SAMA PMC 31.1.
Electromagnetic Interference Effect	According to IEC61326-1:2006, IEC61326-2-3:2006, IEC61000-6-4:2006, IEC61000-6-2:2005.

Physical Specifications	
Electrical Connection	1/2 - 14 NPT, PG 13.5 DIN, and M20 X 1.5.
Material of Construction	Injected low copper aluminum with polyester painting or 316 Stainless Steel housing, with Buna N O'rings on cover (NEMA 4X, IP67).
Mounting	Can be attached directly to the sensor. With an optional bracket can be installed on a 2" pipe or fixed on a wall or panel.
Approximate Weights	Without display and bracket mounting: 0.80 kg Add to the display: 0.13 kg Add to the bracket mounting : 0.60 kg

Control Characteristic	
PID	PID. Proportional Gain: 0 to 100. Integral Time: 0.01 to 999 min/rep. Derivative Time: 0 to 999 s. Direct/Reverse Action. Lower and Upper output limits: -0.6 to +106.25%. Output rate-of-change limit: 0.02 to 600 %/s. Power-on safety output: -0.6 to +106.25%. Antireset windup. Bumpless Auto/Manual transfer. Setpoint Generator up to 16 points, up to 19999 minutes.
Alarm	Dual, trip levels adjustable over entire range. High or Low action. Acknowledge message.

SENSOR	2, 3 or 4 wires					
	TYPE	RANGE °C	RANGE °F	MINIMUM SPAN °C	°C DIGITAL ACCURACY*	
RTD	Cu10 GE	-20 to 250	-4 to 482	50	± 1.0	
	Ni120 Edison Curve #7	-50 to 270	-58 to 518	5	± 0.1	
	Pt50 IEC 751-83 (0.00385)	-200 to 850	-328 to 1562	10	± 0.25	
	Pt100 IEC 751-83 (0.00385)	-200 to 850	-328 to 1562	10	± 0.2	
	Pt500 IEC 751-83 (0.00385)	-200 to 450	-328 to 842	10	± 0.2	
	Pt1000 IEC 751-83 (0.00385)	-200 to 300	-328 to 572	10	± 0.2	
	Pt50 JIS 1604-81 (0.003916)	-200 to 600	-328 to 1112	10	± 0.25	
	Pt100 JIS 1604-81 (0.003916)	-200 to 600	-328 to 1112	10	± 0.25	
	Pt100 MIL-T-24388C (0.00392)	-40 to 540	-40 to 1000	10	± 0.2	
	Ni120 MIL-T-24388C (0.00672)	-40 to 205	-40 to 400	5	± 0.13	
	Pt100 IEC 751-95 (0.00385)	-200 to 850	-328 to 1562	10	± 0.2	
	Pt100 GOST 6651-09 (0.003911)	-200 to 850	-328 to 1562	10	± 0.2	
	Pt50 GOST 6651-09 (0.003911)	-200 to 850	-328 to 1562	10	± 0.2	
	Cu100 GOST 6651-09 (0.00426)	-50 to 200	-58 to 392	10	± 0.15	
	Cu50 GOST 6651-09 (0.00426)	-50 to 200	-58 to 392	10	± 0.15	
THERMOCOUPLE	B NBS Monograph 125	100 to 1800	212 to 3272	50	± 0.5**	
	E NBS Monograph 125	-100 to 1000	-148 to 1832	20	± 0.2	
	J NBS Monograph 125	-150 to 750	-238 to 1382	30	± 0.3	
	K NBS Monograph 125	-200 to 1350	-328 to 2462	60	± 0.6	
	N NBS Monograph 125	-100 to 1300	-148 to 2372	50	± 0.5	
	R NBS Monograph 125	0 to 1750	32 to 3182	40	± 0.4	
	S NBS Monograph 125	0 to 1750	32 to 3182	40	± 0.4	
	T NBS Monograph 125	-200 to 400	-328 to 752	15	± 0.15	
	L DIN 43710	-200 to 900	-328 to 1652	35	± 0.35	
	U DIN 43710	-200 to 600	-328 to 1112	50	± 0.5	
	L GOST 8.585-01	-200 to 800	-328 to 1472	60	± 0.4	
W5Re/W26R ASTM E 988-06	0 to 2200	32 to 3992	60	± 0.5		

Table 6.1 - 2, 3 or 4 wires Sensor Characteristics

* Accuracy of value read on display and accessed by communication. The 4-20 mA accuracy is the digital accuracy ±0.03%

** Not applicable for the first 20% of the range (up to 440 °C).

SENSOR	RANGE mV	MINIMUM SPAN mV	*DIGITAL ACCURACY %
mV	-6 to 22	0.40	± 0.02% or ± 2 µV
	-10 to 100	2.00	± 0.02% or ± 10 µV
	-50 to 500	10.00	± 0.02% or ± 50 µV

Table 6.2 - mV Sensor Characteristics

SENSOR	RANGE Ohm	MINIMUM SPAN Ohm	*DIGITAL ACCURACY %
Ohm	0 to 100	1	± 0.02% or ± 0.01 Ohm
	0 to 400	4	± 0.02% or ± 0.04 Ohm
	0 to 2000	20	± 0.02% or ± 0.20 Ohm

Table 6.3 - Ohm Sensor Characteristics

* Accuracy of value read on display and accessed by communication. The 4-20 mA accuracy is the digital accuracy ±0.03%

** Not applicable for the first 20% of the range (up to 440 °C).

NA Not applicable.

Ordering Code

MODEL												TEMPERATURE TRANSMITTER																																			
COD.												Local Indicator (1)																																			
0						Without Indicator						1						With Digital Indicator																													
COD.												Mounting Bracket																																			
0						Without Bracket						2						316 SST Bracket						A						Flat, 304 SST bracket and 316 SST accessories																	
1						Carbon Steel Bracket						7						Carbon Steel Bracket with 316 SST Fasteners																													
COD.												Electrical Connections																																			
0						1/2 - 14 NPT (3)						3						1/2 - 14 NPT X 1/2 BSP (316 SST) - With adapter (2)						Z						According to user's notes																	
1						1/2 - 14 NPT X 3/4 NPT (316 SST) - With adapter (4)						A						M20 x 1.5 (5)																													
2						1/2 - 14 NPT X 3/4 BSP (316 SST) - With adapter (2)						B						PG 13.5 DIN (6)																													
COD.												Housing Material (8) (9)																																			
H0						Aluminum (IP/TYPE)						H3						316 SST for saline atmosphere (IPW/TYPEX) (10)																													
H1						316 SST (IP/TYPE)						H4						Copper Free Aluminum (IPW/TYPEX) (10)																													
H2						Aluminum for saline atmosphere (IPW/TYPEX) (10)																																									
COD.												Identification Plate																																			
I1						FM: XP, IS, NI, DI						I4						EXAM (DMT): Ex-ia; NEMKO: Ex-d						I6						Without Certification						IE						NEPSI: Ex-ia					
I3						CSA: XP, IS, NI, DI						I5						CEPEL: Ex-d, Ex-ia						I7						EXAM (DMT): Group I, M1 Ex-ia																	
COD.												Tag Plate (7)																																			
J0						With tag, when specified (Default)						J2						User specification																													
J1						Blank																																									
COD.												Sensor Connection																																			
L2						2-wire						LF						Differential																													
L3						3-wire						LB						Backup																													
L4						4-wire																																									
COD.												PID Configuration																																			
M0						With PID (default)						M1						Without PID																													
COD.												LCD1 Indication																																			
Y0						Percentage (default)						Y3						Temperature (Engineering unit)																													
Y1						Current (mA)						YU						User specification																													
COD.												LCD2 Indication																																			
Y0						Percentage (default)						Y6						Temperature (Engineering unit)																													
Y4						Current (mA)						YU						User specification																													
COD.												Painting																																			
P0						Gray Munsell N6.5						P8						Without Painting						P9						Blue Safety Base Epóxi - Electrostatic						Painting											
P1						Safety Blue N4845 (Standard 1374 - Petrobras)																																									
P2						Safety Blue N4845 (Standard 1735 - Petrobras)																																									
P3						Polyester Black																																									
P7						Painting According to Procedure PDM-FAB020-01																																									
COD.												Sensor Type																																			
T1						RTD Cu10 - GE						TK						Thermocouple type L - DIN																													
T2						RTD Ni120 - DIN						TP						Thermocouple type U - DIN																													
T3						RTD PT50 - IEC						TN						100 OHM																													
T4						RTD PT100 - IEC						TO						Special OHM																													
T5						RTD PT500 - IEC						TQ						22 mV																													
T6						RTD PT50 - JIS						TR						100 mV																													
T7						RTD PT100 - JIS						TS						500 mV																													
T8						2K OHM						TT						Special mV																													
T9						400 OHM						TU						RTD PT1000 - IEC																													
TA						Thermocouple type B - NBS						TV						RTD PT100 - MILT																													
TB						Thermocouple type E - NBS						TW						RTD NH120 - MILT																													
TC						Thermocouple type J - NBS						TX						RTD PT100 - IEC																													
TD						Thermocouple type K - NBS						10						RTD PT100 - GOST																													
TE						Thermocouple type N - NBS						11						RTD PR50 - GOST																													
TF						Thermocouple type R - NBS						12						CU100 - GOST																													
TG						Thermocouple type S - NBS						13						CU50 - GOST																													
TH						Thermocouple type T - NBS						TZ						Especial																													

TT301	1	2	0	H1	I1	JO	L2	M0	Y0	Y0	P8	T1
-------	---	---	---	----	----	----	----	----	----	----	----	----

NOTE

- (1) Values limited to 4 1/2 digits; units limited to 5 characters.
- (2) Options not certified for use in hazardous locations.
- (3) Certified for use in hazardous locations (CEPEL, CSA, FM, NEMKO, EXAM)
- (4) Certified for use in hazardous locations (CEPEL, CSA, FM)
- (5) Certified for use in hazardous locations (CEPEL, FM, NEMKO, EXAM)
- (6) Certified for use in hazardous locations (CEPEL, NEPSI, EXAM)
- (7) Rectangular plate in 316 SST.
- (8) IPX8 tested in 10 meters of water column for 24 hours.
- (9) Ingress Protection:

Products	CEPEL	NEMKO / EXAM	FM	CSA	NEPSI
TT300	IP66/68W	IP66/68W	Type 4X/6(6P)	Type 4X	IP67

- (10) IPW/Type tested for 200 hours according to NBR 8094 / ASTM B 117 standard.

CERTIFICATIONS INFORMATION

European Directive Information

Consult www.Smar.com for the EC declarations of conformity and certificates.

Authorized representative/importer located within the Community:

Smar Europe BV De Oude Wereld 116 2408 TM Alphen aan den Rijn Netherlands

ATEX Directive 2014/34/EU - "Equipment for explosive atmospheres" (applicable from 20 April 2016)

The EC-Type Examination Certificate is released by DNV GL Presafe AS (CE2460) and DEKRA EXAM GmbH (CE0158).

Designated certification body that monitors manufacturing and released QAN (Quality Assurance Notification) and QAR (Quality Assessment Report) is Nemko AS (CE0470).

LVD Directive 2014/35/EU – "Low Voltage" (applicable from 20 April 2016)

According to the LVD directive Annex II, electrical equipment for use in an explosive atmosphere is outside the scope of this directive.

According to IEC standard: IEC 61010-1:2010 - Safety requirements for electrical equipment for measurement, control, and laboratory use - Part 1: General requirements.

ROHS Directive 2011/65/EU - "Restriction of the use of certain hazardous substances in electrical and electronic equipment"

For the evaluation of the products the following standards were consulted: EN 50581:2012

EMC Directive 2014/30/EU - "Electromagnetic Compatibility" (applicable from 20 April 2016)

For products evaluation the standard IEC 61326-1:2013 were consulted and to comply with the EMC directive the installation must follow these special conditions:

Use shielded, twisted-pair cable for powering the instrument and signal wiring.

Keep the shield insulated at the instrument side, connecting the other one to the ground.

Hazardous locations general information

Ex Standards:

IEC 60079-0 General Requirements

IEC 60079-1 Flameproof Enclosures "d"

IEC 60079-7 Increased Safe "e"

IEC 60079-11 Intrinsic Safety "i"

IEC 60079-18 Encapsulation "m"

IEC 60079-26 Equipment with equipment protection level (EPL) Ga

IEC 60079-31 Equipment dust ignition protection by enclosure "t"

IEC 60529 Classification of degrees of protection provided by enclosures (IP Code)

IEC 60079-10 Classification of Hazardous Areas

IEC 60079-14 Electrical installation design, selection and erection

IEC 60079-17 Electrical Installations, Inspections and Maintenance

IEC 60079-19 Equipment repair, overhaul and reclamation

ISO/IEC80079-34 Application of quality systems for equipment manufacture

Warning:

Explosions could result in death or serious injury, besides financial damage.

Installation of this instrument in hazardous areas must be in accordance with the local standards and type of protection. Before proceedings with installation make sure that the certificate parameters are in accordance with the classified hazardous area.

Maintenance and Repair

The instrument modification or replaced parts supplied by any other supplier than authorized representative of Smar is prohibited and will void the Certification.

Marking Label

The instrument is marked with type of protection options. The certification is valid only when the type of protection is indicated by the user. Once a particular type of protection is installed, do not reinstall it using any other type of protection.

Intrinsic Safety / Non Incendive application

In hazardous areas with intrinsic safety or or non-incendive requirements, the circuit entity parameters and applicable installation procedures must be observed.

The instrument must be connected to a proper intrinsic safety barrier. Check the intrinsically safe parameters involving the barrier and equipment including the cable and connections. Associated apparatus ground bus shall be insulated from panels and mounting enclosures. Shield is optional, when using shielded cable, be sure to insulate the end not grounded.

Cable capacitance and inductance plus C_i and L_i must be smaller than C_o and L_o of the Associated Apparatus.

It is recommended do not remove the housing covers when powered on.

Explosionproof / Flameproof application

Only use Explosionproof/Flameproof certified Plugs, Adapters and Cable glands.

The electrical connections entries must be connected using a conduit with sealed unit or closed using metal cable gland or metal blanking plug with at least IP66.

Do not remove the housing covers when powered on.

Enclosure

The electronic housing and sensor threads installed in hazardous areas must have a minimum of 6 fully engaged threads.

The covers must be tightening with at least 8 turns, to avoid the penetration of humidity or corrosive gases, and until it touches the housing. Then, tighten more 1/3 turn (120°) to guarantee the sealing.

Lock the housing and covers using the locking screw.

Degree of Protection of enclosure (IP)

IPx8: Second numeral meaning continuous immersion in water under special condition defined as 10m for a period of 24 hours (Ref: IEC60529).

IPW/ TypeX: Supplementary letter W or X meaning special condition defined as saline environment tested in saturated solution of NaCl 5% w/w at 35°C for a period of 200 hours (Ref: NEMA 250/ IEC60529).

For enclosure with IP/IPW/TypeX applications, all NPT threads must apply a proper water-proof sealant (a non-hardening silicone group sealant is recommended).

Hazardous Locations Approvals

FM Approvals (Factory Mutual)

FM18US0182X

XP Class I Division 1, Groups A, B, C, D; T4;

DIP Class II, Class III Division 1, Groups E, F, G

IS Class I, II,III Division 1, Groups A, B, C, D, E, F G

NI Class I, Division 2, Groups A, B, C, D; NIFW

Tamb = +60°C Max; Type 4, 4X, 6

Electrical parameters: 30Vdc

Entity Parameters/Nonincendive Field Wiring Parameters:

Supply terminals: $V_{max} = 30$ V dc, $I_{max} = 110$ mA, $P_i = 825$ mW, $C_i = 0.005$ μ F, $L_i = 0$.

Sensor terminals: $V_{oc} = 6.51$ V, $I_{sc} = 42$ mA, $P_i = 68$ mW, $C_a = 21$ uF, $L_a = 19$ mH

Special conditions for safe use:

The enclosure contains aluminum and is considered to present a potential risk of ignition by impact or friction. Care must be taken during installation and use to prevent impact or friction.

Drawing

102A-0005, 102A-1225, 102A-1352, 102A-1644, 102A-1645, 102A-2119, 102A-2120

DNV GL Presafe AS

Explosion Proof (PRESAFE 20 75160X)

Group II, Category 2 G, Ex db, Group IIC, Temperature Class T6, EPL Gb

Ambient Temperature: -20 °C to +60 °C

Options: IP66W/68W or IP66/68

Special conditions for safe use:

Repairs of the flameproof joints must be made in compliance with the structural specifications provided by the manufacturer.

Repairs must not be made on the basis of values specified in tables 1 and 2 of EN/IEC 60079-1.

The Essential Health and Safety Requirements are assured by compliance with:
EN IEC 60079-0:2018 General Requirements
EN 60079-1:2014 Flameproof Enclosures "d"

Drawing
102A-1526, 102A-1470, 102A-2158, 102A-2159

DEKRA Testing and Certification GmbH

Intrinsic Safety (DMT 01 ATEX E 150)
Group I, Category M2, Ex ia, Group I, EPL Mb
Group II, Category 2 G, Ex ia, Group IIC, Temperature Class T4/T5/T6, EPL Gb

Supply and signal circuit intended for connection to an intrinsically safe 4-20 mA current loop:
 $U_i = 28$ Vdc, $I_i = 93$ mA, $C_i \leq 5$ nF, $L_i = \text{Neg}$

Maximum Permissible power:

Max. Ambient temperature T_a	Temperature Class	Power P_i
85°C	T4	700 mW
75°C	T4	760 mW
44°C	T5	760 mW
50°C	T5	700 mW
55°C	T5	650 mW
60°C	T5	575 mW
65°C	T5	500 mW
70°C	T5	425 mW
40°C	T6	575 mW

Ambient Temperature: $-40^\circ\text{C} \leq T_a \leq +85^\circ\text{C}$

The Essential Health and Safety Requirements are assured by compliance with:
EN 60079-0:2012 + A11:2013 General Requirements
EN 60079-11:2012 Intrinsic Safety "i"

Drawing
102A-1526, 102A-1470, 102A-2158, 102A-2159, 102A-1472, 102A-1528

CEPEL (Centro de Pesquisa de Energia Elétrica)

Segurança Intrínseca (CEPEL 95.0050X)

	
CEPEL 95.0050X Ex ia IIC T5 Ga Ex ia IIIC T100 °C Da	
IP66W/IP68W	IP66/IP68
(aço inox e alumínio Copper Free)	(alumínio)
$T_{amb}: -20^\circ\text{C a } +65^\circ\text{C}$	

Terminais de Alimentação					Terminais dos sensores de temperatura				
$U_i = 30\text{V}$	$I_i = 100\text{ mA}$	$P_i = 0,7\text{ W}$	$C_i = 6,4\text{ nF}$	$L_i = \text{desp}$	$U_o = 5,5\text{ V}$	$I_o = 22\text{ mA}$	$P_o = 30\text{ mW}$	$C_o = 3,6\text{ uF}$	$L_o = 20\text{ mH}$

Prova de Explosão (CEPEL 96.0043)

 <p>CEPEL 96.0043 Ex db IIC T6 Gb Ex tb IIIC T85 °C Db</p>	
IP66W/IP68W	IP66/IP68
(aço inox e alumínio Copper Free)	(alumínio)
T _{amb} : -20 °C a +40 °C	

Observações:

- O número do certificado é finalizado pela letra "X" para indicar que para a versão do Transmissor de temperatura, intrinsecamente seguro, modelo TT301 equipado com invólucro fabricado em liga de alumínio, somente pode ser instalado em "Zona 0", se durante a instalação for excluído o risco de ocorrer impacto ou fricção entre o invólucro e peças de ferro/aço.
- O produto adicionalmente marcado com a letra suplementar "W" indica que o equipamento foi ensaiado em uma solução saturada a 5% de NaCl p/p, à 35 °C, pelo tempo de 200 h e foi aprovado para uso em atmosferas salinas, condicionado à utilização de acessórios de instalação no mesmo material do equipamento e de buíões de aço inoxidável ASTM-A240, para fechamento das entradas roscadas não utilizadas. Os materiais de fabricação dos equipamentos aprovados para letra "W" são: aço inoxidável AISI 316 e alumínio Copper Free SAE 336 pintados (Procedimento P-CQ-FAB764-09) com tinta Resina Poliéster ou Resina Epoxy com espessura da camada de tinta de 70 a 150 µm e 120 a 200 µm, respectivamente, ou pintados com o plano de pintura P1 e P2 (Procedimento P-CQ-FAB-765-05) com tinta Resina Epoxy ou Poliuretano Acrílico Alifático com espessura de camada de tinta de 290 µm a 405 µm e 185 µm a 258 µm, respectivamente.
- Os planos de pintura P1 e P2 são permitidos apenas para equipamento fornecido com plaqueta de identificação com marcação para grupo de gases IIB.
- O grau de proteção IP68 só é garantido se nas entradas roscadas de ½" NPT for utilizado vedante não endurecível à base de silicone conforme Procedimento P-DM-FAB277-06.
- O segundo numeral oito indica que o equipamento foi ensaiado para uma condição de submersão de dez metros por vinte e quatro horas. O acessório deve ser instalado em equipamentos com grau de proteção equivalente.
- As atividades de instalação, inspeção, manutenção, reparo, revisão e recuperação dos equipamentos são de responsabilidade dos usuários e devem ser executadas de acordo com os requisitos das normas técnicas vigentes e com as recomendações do fabricante.

Normas Aplicáveis:

- ABNT NBR IEC 60079-0:2013 Atmosferas explosivas - Parte 0: Equipamentos – Requisitos gerais
- ABNT NBR IEC 60079-1:2016 Atmosferas explosivas - Parte 1: Proteção de equipamento por invólucro à prova de explosão "d"
- ABNT NBR IEC 60079-11:2013 Atmosferas explosivas - Parte 11: Proteção de equipamento por segurança intrínseca "i"
- ABNT NBR IEC 60079-26:2016 Equipamentos elétricos para atmosferas explosivas - Parte 26: Equipamentos com nível de proteção de equipamento (EPL) Ga
- ABNT NBR IEC 60079-31:2014 Atmosferas explosivas - Parte 31: Proteção de equipamentos contra ignição de poeira por invólucros "t"
- ABNT NBR IEC 60529:2017 Graus de proteção para invólucros de equipamentos elétricos (Código IP)

Desenhos

102A1381	TT301 Plaqueta de Identificação CEPEL IP66/68
102A1257	TT301 Plaqueta de Identificação CEPEL IP66W/68W
102A2050	TT301 Plaqueta de Identificação CEPEL IP66/68 IIB P1/P2
102A2049	TT301 Plaqueta de Identificação CEPEL IP66W/68W IIB P1/P2
102A2100	TT301 Plaqueta de Identificação CEPEL IP66/68 Poeira

Identification Plate

FM Approvals (Factory Mutual)

smar TT301 Temperature Transmitter

Nova Smar S/A
Av. Dr Antônio Furlan Jr, 1028
Sertãozinho-SP 14170-480
Brazil

Temp.Class:T4
Tamb. 60°C max.
Vmax. 30 VDC
I max. 110 mA
Ci 5 nF
Li neg

XP CL I, DIV 1, GP A,B,C,D. **Type 4X/6**
DIP CL II,III, DIV 1, GP E,F,G.
IS CL I,II,III, DIV 1, GP A,B,C,D,E,F,G.
NI CL I, DIV 2, GP A,B,C,D; NIFW
Per inst. dwg 102A0005.

FM APPROVED

"The apparatus enclosure may contain aluminum which is considered to constitute a potential risk of ignition by impact or friction. Care must be taken into account during installation and use to prevent impact or friction."

0000000 - 0000 HART  CE 122502

smar TT301 Temperature Transmitter

Nova Smar S/A
Av. Dr Antônio Furlan Jr, 1028
Sertãozinho-SP 14170-480
Brazil

Temp.Class:T4
Tamb. 60°C max.
Vmax. 30 VDC
I max. 110 mA
Ci 5 nF
Li neg

XP CL I, DIV 1, GP A,B,C,D. **Type 4/6**
DIP CL II,III, DIV 1, GP E,F,G.
IS CL I,II,III, DIV 1, GP A,B,C,D,E,F,G.
NI CL I, DIV 2, GP A,B,C,D; NIFW
Per inst. dwg 102A0005.

FM APPROVED

"The apparatus enclosure may contain aluminum which is considered to constitute a potential risk of ignition by impact or friction. Care must be taken into account during installation and use to prevent impact or friction."

0000000 - 0000 HART  CE 135202

smar TT301 Temperature Transmitter

Nova Smar S/A
Av. Dr Antônio Furlan Jr, 1028
Sertãozinho-SP 14170-480 Brazil
Final Assembly is completed in
Houston-TX
USA

Temp.Class:T4
Tamb. 60°C max.
Vmax. 30 VDC
I max. 110 mA
Ci 5 nF
Li neg

XP CL I, DIV 1, GP A,B,C,D. **Type 4/6**
DIP CL II,III, DIV 1, GP E,F,G.
IS CL I,II,III, DIV 1, GP A,B,C,D,E,F,G.
NI CL I, DIV 2, GP A,B,C,D; NIFW
Per inst. dwg 102A0005.

FM APPROVED

"The apparatus enclosure may contain aluminum which is considered to constitute a potential risk of ignition by impact or friction. Care must be taken into account during installation and use to prevent impact or friction."

0000000 - 0000 HART  CE 164403

smar TT301 Temperature Transmitter

Nova Smar S/A
Av. Dr Antônio Furlan Jr, 1028
Sertãozinho-SP 14170-480 Brazil
Final Assembly is completed in
Houston-TX
USA

Temp.Class:T4
Tamb. 60°C max.
Vmax. 30 VDC
I max. 110 mA
Ci 5 nF
Li neg

XP CL I, DIV 1, GP A,B,C,D. **Type 4X/6**
DIP CL II,III, DIV 1, GP E,F,G.
IS CL I,II,III, DIV 1, GP A,B,C,D,E,F,G.
NI CL I, DIV 2, GP A,B,C,D; NIFW
Per inst. dwg 102A0005.

FM APPROVED

"The apparatus enclosure may contain aluminum which is considered to constitute a potential risk of ignition by impact or friction. Care must be taken into account during installation and use to prevent impact or friction."

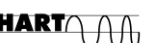
0000000 - 0000 HART  CE 164503

smar ~~BALDOTA~~ TT301 Temperature Transmitter

Nova Smar S/A
Av. Dr Antônio Furlan Jr, 1028
Sertãozinho-SP 14170-480 Brazil
Final Assembly is completed in
Navi Mumbai
IND

Temp.Class:T4
Tamb. 60°C max.
Vmax. 30 VDC
I max. 110 mA
Ci 5 nF
Li neg

XP CL I, DIV 1, GP A,B,C,D. **Type 4/6**
DIP CL II,III, DIV 1, GP E,F,G.
IS CL I,II,III, DIV 1, GP A,B,C,D,E,F,G.
NI CL I, DIV 2, GP A,B,C,D; NIFW
Per inst. dwg 102A0005.

FM APPROVED

"The apparatus enclosure may contain aluminum which is considered to constitute a potential risk of ignition by impact or friction. Care must be taken into account during installation and use to prevent impact or friction."

0000000 - 0000 HART  CE 211900

smar ~~BALDOTA~~ TT301 Temperature Transmitter

Nova Smar S/A
Av. Dr Antônio Furlan Jr, 1028
Sertãozinho-SP 14170-480 Brazil
Final Assembly is completed in
Navi Mumbai
IND

Temp.Class:T4
Tamb. 60°C max.
Vmax. 30 VDC
I max. 110 mA
Ci 5 nF
Li neg

XP CL I, DIV 1, GP A,B,C,D. **Type 4X/6**
DIP CL II,III, DIV 1, GP E,F,G.
IS CL I,II,III, DIV 1, GP A,B,C,D,E,F,G.
NI CL I, DIV 2, GP A,B,C,D; NIFW
Per inst. dwg 102A0005.

FM APPROVED

"The apparatus enclosure may contain aluminum which is considered to constitute a potential risk of ignition by impact or friction. Care must be taken into account during installation and use to prevent impact or friction."

0000000 - 0000 HART  CE 212000

DNV GL Presafe AS / DEKRA Testing and Certification GmbH

smar TT301 Temperature Transmitter

Nova Smar S/A
Av. Dr Antônio Furlan Jr, 1028
Sertãozinho-SP 14170-480
Brazil

Ex II 2G Ex ia IIC T4/T5/T6 Gb DMT 01 ATEX E 150 ()
Pi = 760 mW (T4, Ta = 75°C) -40°C ≤ Ta ≤ +85°C
700 mW (T4, Ta = 85°C) Ui = 28 VDC li = 93 mA IP66
700 mW (T5, Ta = 50°C) Li = neg Ci ≤ 5 nF IP68
575 mW (T6, Ta = 40°C) 10m/24h

Ex III 2G Ex db IIC T6 Gb PRESAFE 20 ATEX 75160X ()
Tamb = -20°C to 60°C U = 28 VDC

0000000 - 0000 HART  CE 0470 147005

smar TT301 Temperature Transmitter

Nova Smar S/A
Av. Dr Antônio Furlan Jr, 1028
Sertãozinho-SP 14170-480
Brazil

Ex II 2G Ex ia IIC T4/T5/T6 Gb DMT 01 ATEX E 150 ()
Pi = 760 mW (T4, Ta = 75°C) -40°C ≤ Ta ≤ +85°C
700 mW (T4, Ta = 85°C) Ui = 28 VDC li = 93 mA IP66W
700 mW (T5, Ta = 50°C) Li = neg Ci ≤ 5 nF IP68W
575 mW (T6, Ta = 40°C) 10m/24h

Ex III 2G Ex db IIC T6 Gb PRESAFE 20 ATEX 75160X ()
Tamb = -20°C to 60°C U = 28 VDC

0000000 - 0000 HART  CE 0470 152605

smar ~~BALDOTA~~ TT301 Temperature Transmitter

Nova Smar S/A
Av. Dr Antônio Furlan Jr, 1028
Sertãozinho-SP 14170-480 Brazil
Final Assembly is completed in
Navi Mumbai IND

Ex II 2G Ex ia IIC T4/T5/T6 Gb DMT 01 ATEX E 150 ()
Pi = 760 mW (T4, Ta = 75°C) -40°C ≤ Ta ≤ +85°C
700 mW (T4, Ta = 85°C) Ui = 28 VDC li = 93 mA IP66
700 mW (T5, Ta = 50°C) Li = neg Ci ≤ 5 nF IP68
575 mW (T6, Ta = 40°C) 10m/24h

Ex III 2G Ex db IIC T6 Gb PRESAFE 20 ATEX 75160X ()
Tamb = -20°C to 60°C U = 28 VDC

0000000 - 0000 HART  CE 0470 215801

smar ~~BALDOTA~~ TT301 Temperature Transmitter

Nova Smar S/A
Av. Dr Antônio Furlan Jr, 1028
Sertãozinho-SP 14170-480 Brazil
Final Assembly is completed in
Navi Mumbai IND

Ex II 2G Ex ia IIC T4/T5/T6 Gb DMT 01 ATEX E 150 ()
Pi = 760 mW (T4, Ta = 75°C) -40°C ≤ Ta ≤ +85°C
700 mW (T4, Ta = 85°C) Ui = 28 VDC li = 93 mA IP66W
700 mW (T5, Ta = 50°C) Li = neg Ci ≤ 5 nF IP68W
575 mW (T6, Ta = 40°C) 10m/24h

Ex III 2G Ex db IIC T6 Gb PRESAFE 20 ATEX 75160X ()
Tamb = -20°C to 60°C U = 28 VDC

0000000 - 0000 HART  CE 0470 215901

smar TT301 Temperature Transmitter
 BR - 14160
 Sertãozinho
 Brazil

Ex I M2 Ex ia I Mb DMT 01 ATEX E 150
 $-40^{\circ}\text{C} \leq T_a \leq +85^{\circ}\text{C}$
 Pi = 700 mW
 Ui = 28 VDC li = 93 mA Li = neg Ci \leq 5 nF

IP 66 68

0000000 - 0000 HART CE 0470 **147201**

smar TT301 Temperature Transmitter
 BR - 14160
 Sertãozinho
 Brazil

Ex I M2 Ex ia I Mb DMT 01 ATEX E 150
 $-40^{\circ}\text{C} \leq T_a \leq +85^{\circ}\text{C}$
 Pi = 700 mW
 Ui = 28 VDC li = 93 mA Li = neg Ci \leq 5 nF

IP 66W 68W

0000000 - 0000 HART CE 0470 **152801**

CEPEL (Centro de Pesquisa de Energia Elétrica)

smar TT301 Transmissor de Temperatura
 Nova Smar S/A
 Av. Dr. Antônio Furlan Jr
 1028 Sertãozinho-SP
 14170-480
 Brazil

Ex db IIC T6 Gb CEPEL 96.0043 ()
 Ex ia IIC T5 Ga CEPEL 95.0050 X ()
 Tamb= -20° a 65°C
 Ui= 30V li= 100mA Pi= 0,7W
 Ci= 6,4nF Li= 0

Segurança
 Eletrobras
 INMETRO

IP 66 68

0000000 - 0000 HART CE **138102**

smar TT301 Transmissor de Temperatura
 Nova Smar S/A
 Av. Dr. Antônio Furlan Jr
 1028 Sertãozinho-SP
 14170-480
 Brazil

Ex db IIC T6 Gb CEPEL 96.0043 ()
 Ex ia IIC T5 Ga CEPEL 95.0050 X ()
 Tamb= -20° a 65°C
 Ui= 30V li= 100mA Pi= 0,7W
 Ci= 6,4nF Li= 0

Segurança
 Eletrobras
 INMETRO

IP 66W 68W

0000000 - 0000 HART CE **125702**

smar TT301 Transmissor de Temperatura
 Nova Smar S/A
 Av. Dr. Antônio Furlan Jr
 1028 Sertãozinho-SP
 14170-480
 Brazil

Ex db IIB T6 Gb CEPEL 96.0043 ()
 Ex ia IIB T5 Ga CEPEL 95.0050 X ()
 Tamb= -20° a 65°C
 Ui= 30V li= 100mA Pi= 0,7W
 Ci= 6,4nF Li= 0

Segurança
 Eletrobras
 INMETRO

IP 66 68
 P1/P2
 Pintura

0000000 - 0000 HART CE **205001**

smar TT301 Transmissor de Temperatura
 Nova Smar S/A
 Av. Dr. Antônio Furlan Jr
 1028 Sertãozinho-SP
 14170-480
 Brazil

Ex db IIB T6 Gb CEPEL 96.0043 ()
 Ex ia IIB T5 Ga CEPEL 95.0050 X ()
 Tamb= -20° a 65°C
 Ui= 30V li= 100mA Pi= 0,7W
 Ci= 6,4nF Li= 0

Segurança
 Eletrobras
 INMETRO

IP 66W 68W
 P1/P2
 Pintura

0000000 - 0000 HART CE **204901**

smar TT301 Transmissor de Temperatura
 Nova Smar S/A
 Av. Dr. Antônio Furlan Jr
 1028 Sertãozinho-SP
 14170-480
 Brazil

Ex tb IIIC T85°C Db CEPEL 96.0043 ()
 Ex ia IIIC T100°C Da CEPEL 95.0050 X ()
 Tamb= -20° a 50°C
 Ui= 30V li= 100mA Pi= 0,7W
 Ci= 6,4nF Li= 0

Segurança
 Eletrobras
 INMETRO

IP 66 68

0000000 - 0000 HART CE **210001**

FM Approvals (Factory Mutual)

NON HAZARDOUS OR DIVISION 2 AREA

SAFE AREA APPARATUS

UNSPECIFIED, EXCEPT THAT IT MUST NOT BE SUPPLIED FROM, NOR CONTAIN UNDER NORMAL OR ABNORMAL CONDITIONS, A SOURCE OF POTENTIAL IN RELATION TO EARTH IN EXCESS OF 250VAC OR 250VDC.

HAZARDOUS AREA

REQUIREMENTS:

- 1 -- INSTALLATION TO BE IN ACCORDANCE WITH ANSI/ISA RP12.06.01 "INSTALLATION OF INTRINSICALLY SAFE SYSTEMS FOR HAZARDOUS (CLASSIFIED) LOCATIONS" AND THE NATIONAL ELECTRICAL CODE (ANSI/NFPA 70).
- 2 -- ASSOCIATED APPARATUS GROUND BUS MUST BE INSULATED FROM HAZARDOUS AREAS GROUND BUS.
- 3 -- RESISTANCE BETWEEN INTRINSICALLY SAFE GROUND AND EARTH GROUND MUST BE LESS THAN 1.0 (ONE) OHM.
- 4 -- WIRES: TWISTED PAIR, 22AWG OR LARGER.
- 5 -- SHIELD IS OPTIONAL AND IF USED, BE SURE TO INSULATE THE END NOT GROUND.
- 6 -- CABLE CAPACITANCE AND INDUCTANCE PLUS C_i AND L_i MUST BE SMALLER THAN C_a AND L_a OF THE ASSOCIATED APPARATUS.

INTRINSICALLY SAFE APPARATUS
 ENTITY VALUES: C_i=5nF L_i=8uH V_{max}=30VDC I_{max}=110mA
 CLASS I,II,III DIV.1, GROUPS A,B,C,D,E,F & G
 MODEL TT301 -- SERIES TEMPERATURE TRANSMITTER.

NO REVISION TO DRAWING WITHOUT FM APPROVAL.
 WARNING: SUBSTITUTION OF COMPONENTS MAY IMPAIR INTRINSIC SAFETY.
 WARNING: TO PREVENT IGNITION OF FLAMMABLE OR COMBUSTIBLE ATMOSPHERES, DISCONNECT POWER BEFORE SERVICING.
 WARNING: THE APPARATUS ENCLOSURE CONTAINS ALUMINUM AND IS CONSIDERED TO CONSTITUTE A POTENTIAL RISK OF IGNITION BY IMPACT OR FRICTION. CARE MUST BE TAKEN INTO ACCOUNT DURING INSTALLATION AND USE TO PREVENT IMPACT OR FRICTION.

ENTITY PARAMETERS FOR ASSOCIATED APPARATUS
 CLASS I,II,III DIV.1, GROUPS A,B,C,D,E,F & G
 C_a >5nF + CABLE CAPACITANCE
 L_a >8uH + CABLE CAPACITANCE
 V ≤30V
 I ≤110mA

APPROVED

APPROVAL CONTROLLED BY WEBCONTDOC				DRAWN	CHECKED	PROJECT	APPROVAL
03	VALDECIR 17/05/17	ENIO 17/05/17	ALT 0515/15	MOACIR 22/07/93	BASILIO 22/07/93	SINASTRE 22/07/93	MISSAWA 22/07/93
02	MELONI 28/07/15	GRATON 28/07/15	ALT 0515/15	EQUIPMENT: TT301 CONTROL DRAWING			
01	J.RODRIGO 20/09/05	GRATON 20/09/05	ALT-DE 0077/05				
REV	BY	APPROVAL	DOC				

CONTROLLED BY DIGITAL MEDIA	
NUMBER 102A000503	
SCALE -	SHEET 01/01

Appendix B

		SRF–SERVICE REQUEST FORM		Proposal No.:	
Company:		Unit:		Receipt of Remittance:	Warranty Yes () Purchase Order:
					No ()
COMMERCIAL CONTACT			TECHNICAL CONTACT		
Full name:			Full name:		
Position:			Position:		
Phone:		Extension:	Phone:		Extension:
Fax:			Fax:		
Email:			Email:		
EQUIPMENT DATA / TEMPERATURE SENSOR					
Model: TT301 () TT302 () TT303 () TT400SIS () TT411 () TT421 ()		Serial Number:		Sensor Type and Connection: Measurement type: () Double Sensor () Average between Sensors () Differential () Backup () Single	
INFORMATION AND DESCRIPTION OF THE FAILURE					
Environment Temperature (°C)		Work Temperature (°C)		Calibration Range	
Min:	Max:	Min :	Max:	Min:	Max:
Operation Time:			Failure Data:		
IMPORTANT COMMENTS ABOUT EQUIPMENT APPLICATION AND PROCESS (Please, inform more details about the application, installation, etc.).					
FAILURE DESCRIPTION OR BAD OPERATION (Please, describe the behavior of the fail, if it is repetitive, how it exactly happens, and so on.)					
NOTES					
For warranty or non-warranty repair, please contact your representative. Further information about address and contacts can be found on www.smar.com/contactus.asp .					

SMAR WARRANTY CERTIFICATE

1. SMAR guarantees the equipment of its own manufacture for a period of 24 (twenty four) months, starting on the day the invoice is issued. The guarantee is effective regardless of the day the product was installed. Third-party equipment and software are not included in this Term of Guarantee and Smar does not offer any guarantee or declaration in the name of the manufacturer. Any guarantees related to these products are the supplier or licensor responsibility.
2. SMAR products are guaranteed against any defect originating from manufacturing, mounting, whether of a material or manpower nature, provided that the technical analysis reveals the existence of a quality failure liable to be classified under the meaning of the word, duly verified by the technical team within the warranty terms.
3. Exceptions are proven cases of inappropriate use, wrong handling or lack of basic maintenance compliant to the equipment manual provisions. SMAR does not guarantee any defect or damage caused by an uncontrolled situation, including but not limited to negligence, user imprudence or negligence, natural forces, wars or civil unrest, accidents, inadequate transportation or packaging due to the user's responsibility, defects caused by fire, theft or stray shipment, improper electric voltage or power source connection, electric surges, violations, modifications not described on the instructions manual, and/or if the serial number was altered or removed, substitution of parts, adjustments or repairs carried out by non-authorized personnel; inappropriate product use and/or application that cause corrosion, risks or deformation on the product, damages on parts or components, inadequate cleaning with incompatible chemical products, solvent and abrasive products incompatible with construction materials, chemical or electrolytic influences, parts and components susceptible to decay from regular use, use of equipment beyond operational limits (temperature, humidity, etc.) according to the instructions manual. In addition, this Warranty Certificate excludes expenses with transportation, freight, insurance, all of which are the customer's responsibility.
4. For warranty or non-warranty repair, please contact your representative.

Further information about address and contacts can be found on www.smar.com/contactus.asp
5. In cases needing technical assistance at the customer's facilities during the warranty period, the hours effectively worked will not be billed, although SMAR shall be reimbursed from the service technician's transportation, meals and lodging expenses, as well dismantling/mounting costs, if any.
6. The repair and/or substitution of defective parts do not extend, under any circumstance, the original warranty term, unless this extension is granted and communicated in writing by SMAR.
7. No Collaborator, Representative or any third party has the right, on SMAR's behalf, to grant warranty or assume some responsibility for SMAR products. If any warranty would be granted or assumed without SMAR's written consent, it will be declared void beforehand.
8. Cases of Extended Warranty acquisition must be negotiated with and documented by SMAR.
9. If necessary to return the equipment or product for repair or analysis, contact us.
See item 4.
10. In cases of repair or analysis, the customer must fill out the Revision Requisition Form (FSR) included in the instructions manual, which contains details on the failure observed on the field, the circumstances it occurred, in addition to information on the installation site and process conditions. Equipments and products excluded from the warranty clauses must be approved by the client prior to the service execution.
11. In cases of repairs, the client shall be responsible for the proper product packaging and SMAR will not cover any damage occurred in shipment.

Smar Warranty Certificate

12. In cases of repairs under warranty, recall or outside warranty, the client is responsible for the correct packaging and packing and SMAR shall not cover any damage caused during transportation. Service expenses or any costs related to installing and uninstalling the product are the client's sole responsibility and SMAR does not assume any accountability before the buyer.
13. It is the customer's responsibility to clean and decontaminate products and accessories prior to shipping them for repair, and SMAR and its dealer reserve themselves the right to refuse the service in cases not compliant to those conditions. It is the customer's responsibility to tell SMAR and its dealer when the product was utilized in applications that contaminate the equipment with harmful products during its handling and repair. Any other damages, consequences, indemnity claims, expenses and other costs caused by the lack of decontamination will be attributed to the client. Kindly, fill out the Declaration of Decontamination prior to shipping products to SMAR or its dealers, which can be accessed at www.smar.com/doc/declarationofcontamination.pdf and include in the packaging.
14. This warranty certificate is valid only when accompanying the purchase invoice.